

The Bystronic logo consists of the word "Bystronic" in a white, bold, sans-serif font, positioned in the upper left corner of a solid red square. The letter "y" is partially obscured by a white, diamond-shaped graphic composed of a grid of small dots.

Bystronic

Best choice.

Bystronic Tools

Our Tools RF-A

Laser | Bending | Waterjet
bystronic.com

Overview about the icons used in this catalogue



Material / Hardness



max. permitted load



method of tool loading



nature of load



max. box depth



weight



availability / delivery time



clamping type



drawing number (BOSbase reference)



reversible tool



bottom tool support

Content

Basics.....	4
Bending methods.....	4
Calculations for air bending.....	10
Recommendation starter kits	16
Upper tools RF-A	18
Description upper tool	18
Segmentation of punches	22
Upper tools RF-A	23
Bottom tools RF-A	79
Lower table options.....	80
Segmentation of bottom tools	84
Bottom tools	86
Hemming tools	102
Special applications.....	106
Workshop (ByAcademy)	108
Bystronic world wide	110

Bystronic bending methods

Air bending

For material thicknesses
up to 50 mm mild steel

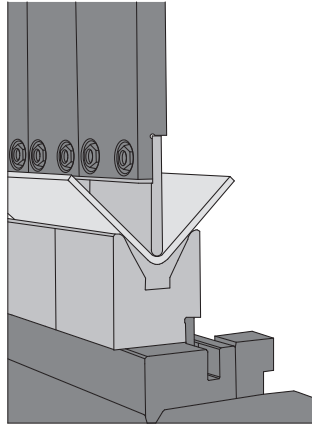

Coining

For material thicknesses
up to 3 mm mild steel

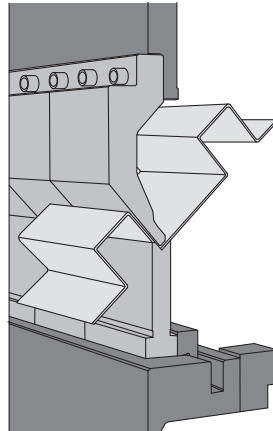

Bystronic bending methods

3-point-bending

Up to 12 mm mild steel

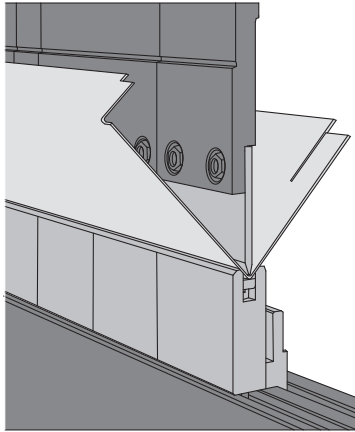

Bystronic bending methods

Principle of air bending

With the air bending method the bending angle is determined by the depth of penetration of the upper tool into the lower die. To that effect and amongst other factors the bending accuracy is mainly dependant upon the positional accuracy of the upper beam. Under load the material is stressed from A to C. After removal of the load the portions AD and EC spring back into thier original positions. In the case of ari bending without bottoming the vees of the bottom tool and the angle of the top tool must be smaller than 90° .

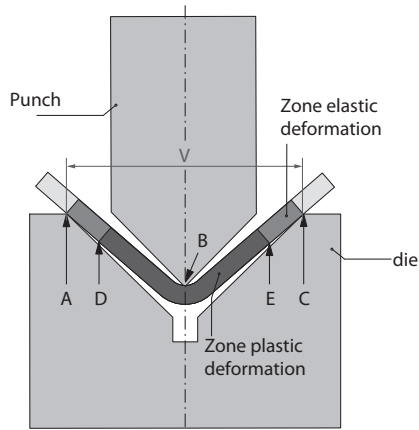

- M = bottom tool
- R = inner radius
- V = bottom tool opening
- S = upper tool

Bystronic bending methods

Principle of bottoming

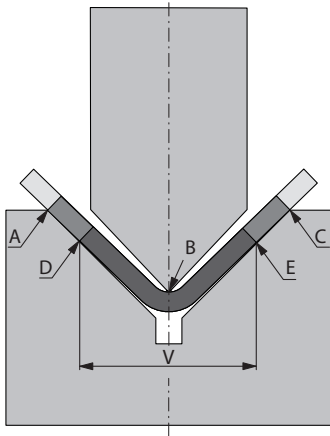

As soon as the areas AD and CE touch the sides of the vee in air bending with bottoming they will spring back into their original position until the positions of contact have to move to D and E.

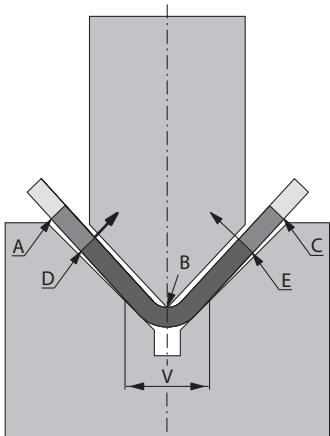

A still further penetration of the top tool will result in a disengagement of the points D and E from the lower die as the points of contact start to move in the overbending is larger than the spring back of the portion located underneath the points of contact the angle of the section after removal of the load will be smaller than the angle of the vee..

Bystronic bending methods

Principle of coining

A further penetration of the top tool will result in a reopening of the section D and E until the top tool completely bottoms out on to the material. (start of the coining process).

The variation of the forces versus the travel of the top tool is a function of the material. The bottoming or coining process corresponds to a continuous reduction of the die opening (V). The smaller the width of the vee during coining results in a corresponding reduction of spring back in comparison to airbending. The bending forces required are 4 to 8 times greater than those required for air bending.

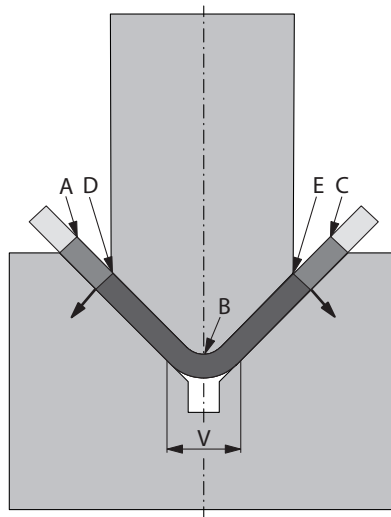

Bystronic bending methods

Principle of 3-pont-bending

For the 3-point-bending the bottom tool groove depth (H) is accomplished with an accuracy of 1/1000 mm by means of a precise wedge system. With given sheet metal quality, sheet metal characteristics and plate thickness and taking resilience of the part into account, the bend angle to be produced is governed predictably and accurately by bottom tool depth (F). The top tool segments positioned along the bending line thereby adapts to the bending line of the bottom tools. The hydraulic cushion compensates for machine and material related factors.

The 3-point-bending process is something in between air bending and coining and delivers highest accuracy and flexibility. It opens new possibilities in designing and manufacturing of parts.

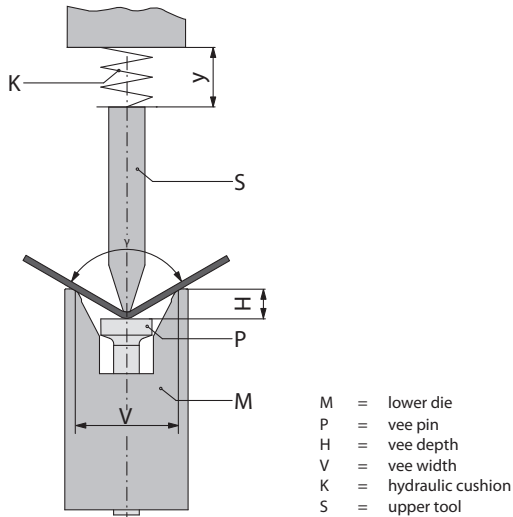

Calculation basics for air bending

Capacity chart for air bending

The given data has been calculated based upon bending material with a tensile strength of $R_m = 420 \text{ N/mm}^2$ over a length of 1 m.

V	6	8	10	12	16	18	20	24	32	40	50	60	80
R	1	1.2	1.6	2	2.5	2.8	3	3.5	5	6	8	9.5	12
t	Bending force force in kN/1 m bending length												
a	Minimum flange length in mm												
0.5	25												
	4.3												
0.8	70	48											
	4.6	5.7											
1	115	80	60										
	5	6	7										
1.2		120	90	70									
		6	7.5	8.5									
1.5			150	120									
			8	9									
2.0				235	160	135	120	95					
				10	12	13	14.5	17					
2.5					265	225	200	155	110				
					12.5	14	15.5	17.5	23				
3.0							300	240	165	125			
							15.5	17.5	23.5	28			
4.0									315	235	180		
									25	29	35		
5.0									535	430	310	250	
									26	31	35.5	43	
6.0										610	450	360	
										32	36	44	
8.0											880	690	470
											40	46	57
10													800
													60
12													1200
													62
16													
18													
20													

Sheets with mill scale will increase the bending force by a factor of 1,05–1,1

Calculation basics for air bending

Capacity chart for air bending

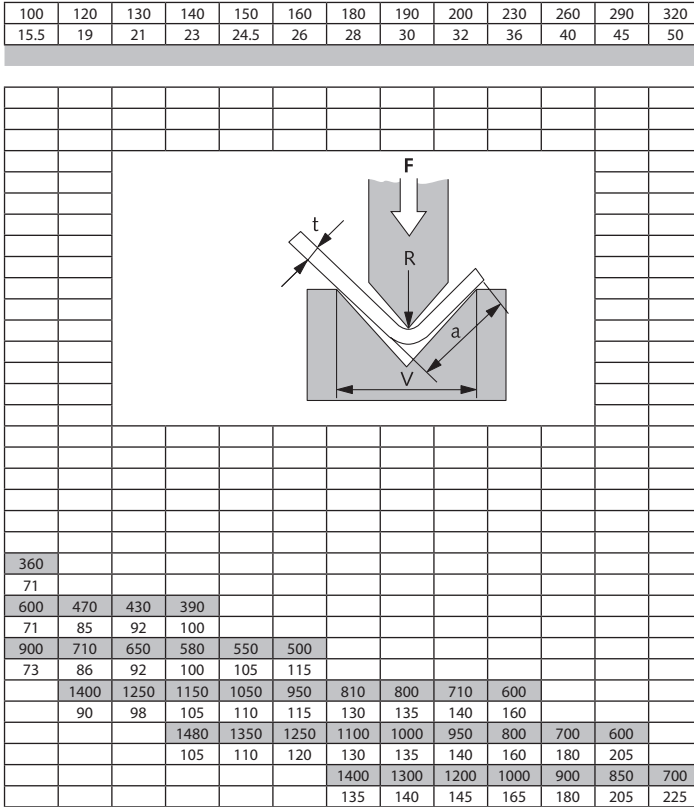

The internal radius R corresponds to approximately 16% of the die opening V .

Calculation basics for air bending

Calculation formulas

Recommended bottom tool opening V for air bending

Material thickness	t	0.5–2.5 mm	3–8 mm	9–10 mm	> 12 mm
Bottom tool opening	V	6 × t	8 × t	10 × t	12 × t

Bending force for

Aluminium	$R_m = 300 \text{ N/mm}^2$	$F = F(\text{table}) \times 0.65$
Mild steel	$R_m = 420 \text{ N/mm}^2$	$F = F(\text{table})$
Stainless steel	$R_m = 700 \text{ N/mm}^2$	$F = F(\text{table}) \times 1.6$

Determination of the bending force for air bending (reference data)

$$F = \frac{R_m \times t^2}{V} \times \left(1 + \frac{4 \times t}{V}\right)$$

Conversion: $R_m = \text{tensile strenght in N/mm}^2$

10 N \cong 1 kg

10 kN \cong 1 t

Conversion for minimal internal radii R

thickness t	1	2	3	4	5	6	8	10	12	16	18	20
min. R	1	2	3	5	6	8	12	16	20	28	36	40

Calculation basics for air bending

Tensile strength

Material		Tensile strength	
American	European	KPSI	N/mm ²
6061 Aluminum	Alu 50	42	290
5052 Aluminum	Alu 35	44	303
1010 Mild steel	DC01	53	366
A 536-80 G 60-40-18	GGG-40	58	400
A 351 G CF 8	G-X 6CrNi 18 9	65	450
A 572 G50	S 355 MC	80	550
Domex 80	S 420 MC	80	550
A 36	S 235 JR	80	552
304 Stainless	Inox V2A	85	586
316 Stainless	Inox V4A	87	600
A 572 G 65	S 460 MC	95	655
Domex 100	S 500 MC	102	700
Domex 550	S 550 MC	110	760
Domex 600	S 600 MC	119	820
Weldox 700	Weldox 700	123	850
Domex 650	S 650 MC	128	880
Domex 700	S 700 MC	138	950
4140 Low alloy	42 CrMo 4	145	1000
Weldox 900	Weldox 900	149	1030
Weldox 960	Weldox 960	154	1060
Hardox 400	Hardox 400	181	1250
Hardox 500	Hardox 500	225	1550

Please ask your responsible Consultant for bending high strength materials.

Calculation basis for air bending

Working space determination

Tonnage	Day-light	Day-light	Stroke	Punch height	Working height	Clamping height	Box depth	Die height	Table height	Free space	Width upper beam
	DL mm	DLW mm	SH mm	PH mm	WH mm	CH mm	BH mm	DH mm	TH mm	FS mm	UB mm
		Modufix				**				*	
		Wila				**					
60t	500	420	215	155	116	39	53.2	55	145	184	80
				175	115	60	52.5	55	145	185	80
				250	190	60	105	55	145	110	80
100t	500	420	215	155	116	39	56.7	55	145	184	70
				175	115	60	56	55	145	185	70
				250	190	60	108.5	55	145	110	70
150t	500	420	215	155	116	39	56.7	55	145	184	70
				175	115	60	56	55	145	185	70
				250	190	60	108.5	55	145	110	70
200t	500	420	215	155	116	39	53.2	55	145	184	80
				175	115	60	52.5	55	145	185	80
				250	190	60	105	55	145	110	80
250t	550	470	265	155	116	39	53.2	55	145	234	80
				175	115	60	52.5	55	145	235	80
				250	190	60	105	55	145	160	80
320t	550	470	265	155	116	39	46.2	55	145	234	100
				175	115	60	54.5	55	145	235	100
				250	190	60	98	55	145	160	100

* Not valid for WILA Modufix,

** Clamping height S/R/Wila = 39, RF/RF-A = 60

Calculation formula

for box depth. $BH = (PH - CH - UB : 2) \times 0,7$

To calculate the remaining working day light for given machine and tool combination. $FS = DL - TH - DH - WH$

Calculation basics for air bending

Working space determination

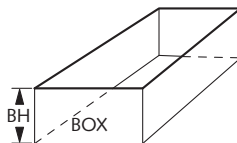
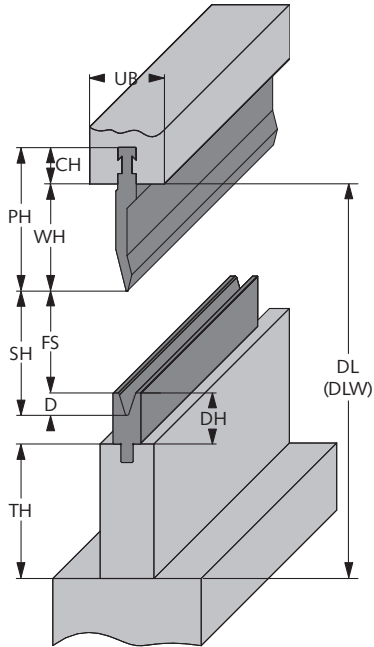

Recommendation starter kits 60 - 320 t/machines

Bend lengtht	Part number	Designation	Pieces	Unit
2050 mm	65206.0005.5007	Punch P5 RF-A/30° L=515	4	pieces
	65206.0005.0003	Punch P5 RF-A/30° L=1000 sect. FSC	1	piece
	64201.0012.3009	Die V12/30° L=1030	2	pieces
	64201.0012.0002	Die V12/30° L=1000 sect.FSC	1	piece
2550 mm	65206.0005.5007	Punch P5 RF-A/30° L=515	5	pieces
	65206.0005.0003	Punch P5 RF-A/30° L=1000 sect. FSC	1	piece
	64201.0012.3009	Die V12/30° L=1030	2	pieces
	64201.0012.0002	Die V12/30° L=1000 sect.FSC	1	piece
3100 mm	65206.0005.5007	Punch P5 RF-A/30° L=515	6	pieces
	65206.0005.0003	Punch P5 RF-A/30° L=1000 sect. FSC	1	piece
	64201.0012.3009	Die V12/30° L=1030	3	pieces
	64201.0012.0002	Die V12/30° L=1000 sect.FSC	1	piece
4100 mm	65206.0005.5007	Punch P5 RF-A/30° L=515	8	pieces
	65206.0005.0003	Punch P5 RF-A/30° L=1000 sect. FSC	1	piece
	64201.0012.3009	Die V12/30° L=1030	4	pieces
	64201.0012.0002	Die V12/30° L=1000 sect.FSC	1	piece

Notes

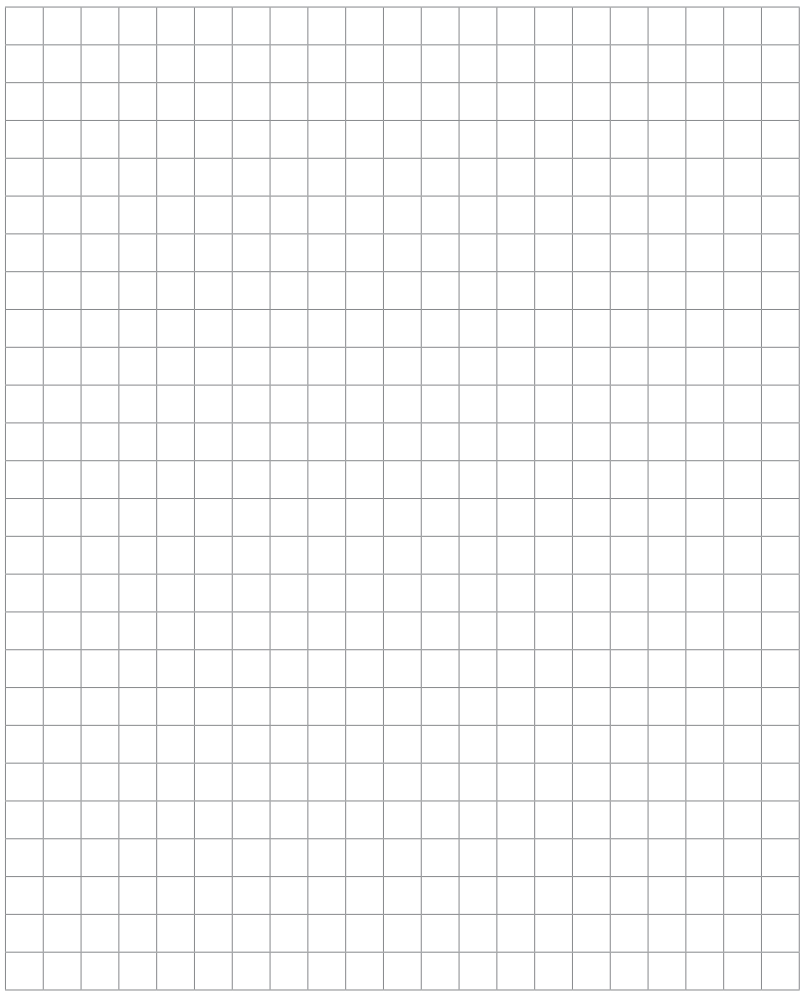

Description upper tools

Clamping R

R mechanical

R hydraulic

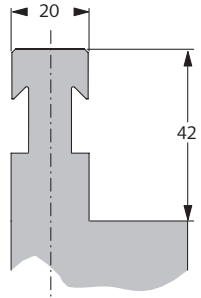
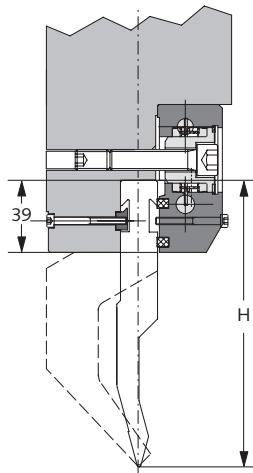
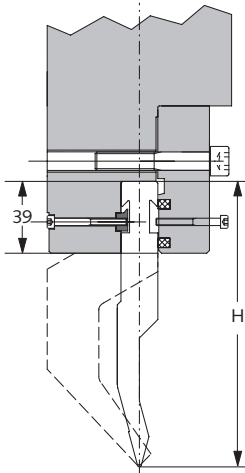

 Head support ≤ 1600 kN/m shoulder supp. > 1600 kN/m

 Sideways and vertical insertion possible

 Head and shoulder supported possible

 Mechanical and hydraulic

 Tools are reversable

Because of the height of the clamping area, R type is suitable for light - medium duty clamping applications.

Description upper tools

Clamping RF

RF mechanical

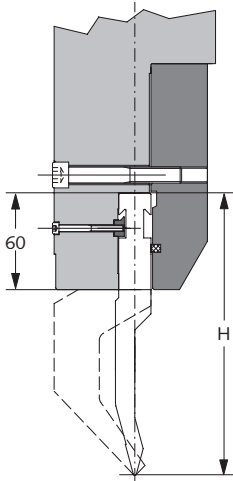

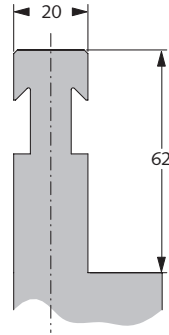
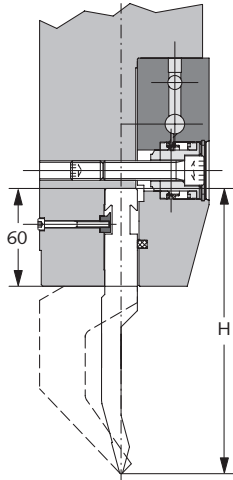

RF hydraulic



 Head support $\leq 1600 \text{ kN/m}$ shoulder supp. $> 1600 \text{ kN/m}$

 Sideways and vertical insertion possible

 Head and shoulder supported possible

 Mechanical and hydraulic

 Tools are reversible

Because of the height the RF type clamping is suitable for medium to high applications.

Description upper tools

Clamping RF-A

RF-A hydraulic

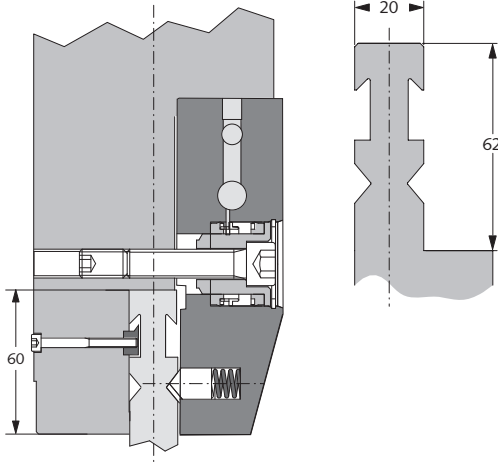

The automatic centering of the RF-A hydraulic clamping system helps to shorten the setup time by up to 20%. This combined with the large clamping area makes it a very popular option among users of both Xpert 60-320 machines and also the large Xpert machines 250 - 1000

 Head support ≤ 1600 kN/m shoulder supp. > 1600 kN/m

 Sideways and vertical insertion possible

 Head and shoulder supported possible

 Hydraulic

 Tools are reversible

Maximum tool weight
50 kg / m

Description upper tools

Clamping MAMMUT Ergo

MAMMUT Ergo hydraulic

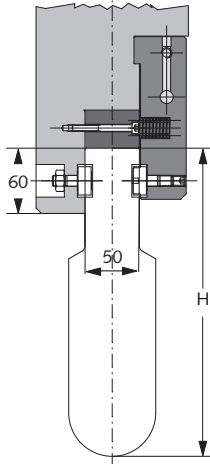

Head supported ≤ 3200 kN/m shoulder su. > 3200 kN/m



Sideways insertion



Head and shoulder supported possible



Hydraulic



Tools are reversible

The MAMMUT Ergo is specially designed for high loads and the use of heavy tools. The MAMMUT Ergo is designed with casters for easy and quick tooling setup.

Segmentation of punches

Horns R / RF / RF-A

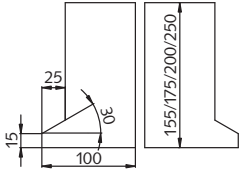

FSC / 1000 mm

(10 + 15 + 20 + 30 + 50 + 100 + 200 + 275 + 300)



FSW / 550 mm) *

(20 + 25 + 30 + 35 + 40 + 200 + 100HL + 100HR)

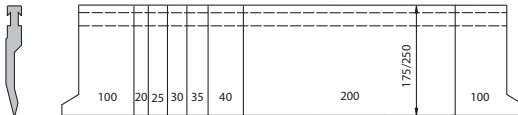

* Punch P12 and also all radius inserts are without horn pieces.
This pieces are replaced by 2x100mm pieces.

Upper tools RF-A

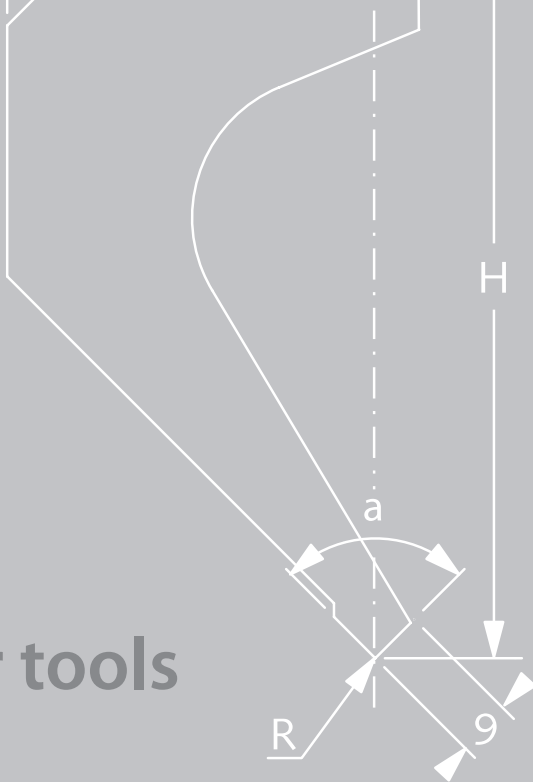

P2 RF-A H175



[R] Radius (mm) 1

Nose angle 85°

[H] Height (mm) 175

 42 CrMo 4

 58 - 62 HRC

 $F_{max} = 1300 \text{ kN/m}$

 Operator side

 Head supported

 24.1 kg/m

 Hydraulic clamping

 45.5 mm

 Ex stock / 24 h

 BOS No. BY1C003

Standard length	Part number
515 mm	65206.0002.5001
1030 mm	65206.0002.3004
1000 mm sect. FSC	65206.0002.0003
550 mm sect. FSW	65206.0002.9001
Horn set LH + RH	65206.0002.7001

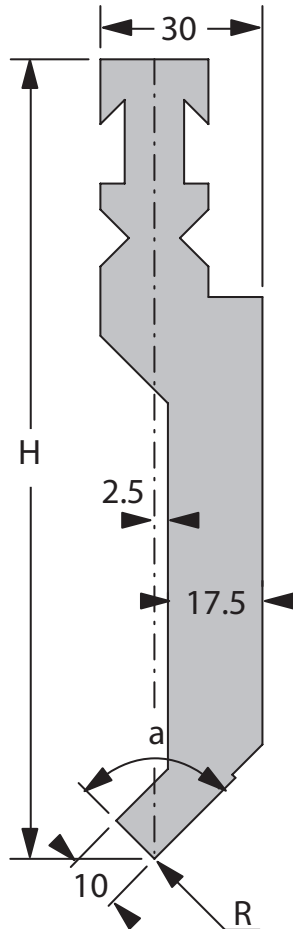

P2 RF-A / 85°
F = 1300 kN/m
R = 1 mm
H = 175 mm

P2 RF-A H250



[R] Radius (mm) 1

Nose angle 85°

[H] Height (mm) 250

 42 CrMo 4

 58 - 62 HRC

 Fmax = 1000 kN/m

 Operator side

 Head supported

 34.4 kg/m

 Hydraulic clamping

 98.0 mm

 Ex stock / 24 h

 BOS No. BY1C004

Standard length	Part number
515 mm	65206.0002.5005
1030 mm	65206.0002.3009
1000 mm sect. FSC	65206.0002.0001
550 mm sect. FSW	65206.0002.9002
Horn set LH + RH	65206.0002.7003

P3 RF-A H175



[R] Radius (mm) 1

Nose angle 85°

[H] Height (mm) 175

 42 CrMo 4

 58 - 62 HRC

 F_{max} = 1300 kN/m

 Operator side

 Head supported

 24.5 kg/m

 Hydraulic clamping

 45.5 mm

 Ex stock / 24 h

 BOS No. IB00545

Standard length	Part number
515 mm	65206.0003.5005
1030 mm	65206.0003.3001
1000 mm sect. FSC	65206.0003.0002
550 mm sect. FSW	65206.0003.9001
Horn set LH + RH	65206.0003.7006

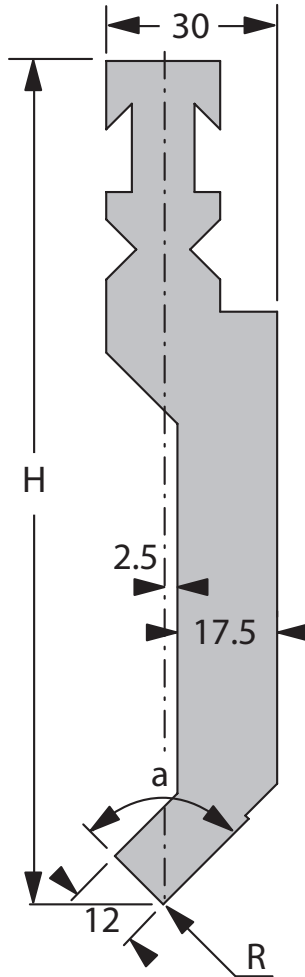

P3 RF-A / 85°
 $F = 1300 \text{ kN/m}$
 $R = 1 \text{ mm}$
 $H = 175 \text{ mm}$

P3 RF-A H250



[R] Radius (mm) 1

Nose angle 85°

[H] Height (mm) 250

 42 CrMo 4

 58 - 62 HRC

 Fmax = 1400 kN/m

 Operator side

 Head supported

 34.8 kg/m

 Hydraulic clamping

 98.0 mm

 Ex stock / 24 h

 BY10176

Standard length

Part number

515 mm

65206.0003.5003

1030 mm

65206.0003.3004

1000 mm sect. FSC

65206.0003.0009

550 mm sect. FSW

65206.0003.9002

Horn set LH + RH

65206.0003.7002

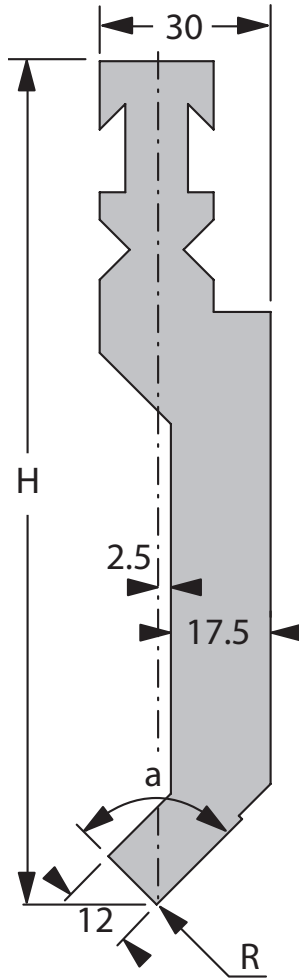

P3 RF-A / 85°
F = 1400 kN/m
R = 1 mm
H = 250 mm

P4 RF-A H175

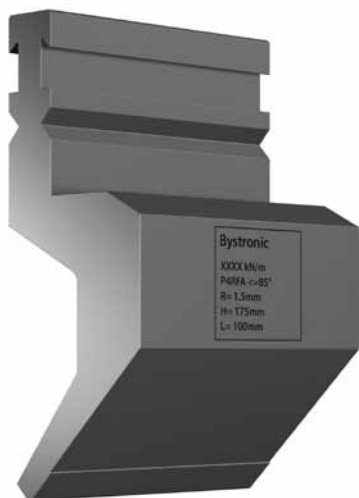

[R] Radius (mm) 1.5

Nose angle 85°

[H] Height (mm) 175

 42 CrMo 4

 58 - 62 HRC

 $F_{max} = 900 \text{ kN/m}$

 Operator side

 Head supported

 31.8 kg/m

 Hydraulic clamping

 45.5 mm

 Ex stock / 24 h

 BOS No. BY1C011A

Standard length	Part number
515 mm	65206.0004.5005
1030 mm	65206.0004.3005
1000 mm sect. FSC	65206.0004.0003
550 mm sect. FSW	65206.0004.9001
Horn set LH + RH	65206.0004.7002

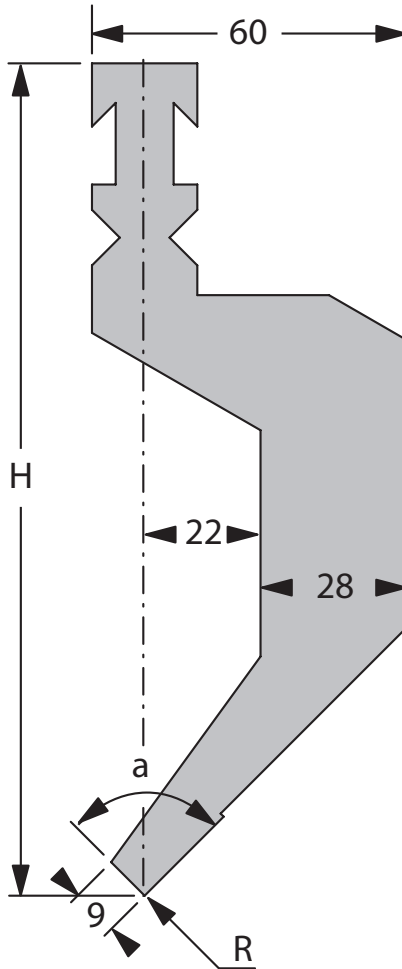

P4 RF-A / 85
 $F = 900 \text{ kN/m}$
 $R = 1.5 / 1 \text{ mm}$
 $H = 175 \text{ mm}$

P4 RF-A H250



[R] Radius (mm) 1.5

Nose angle 85°

[H] Height (mm) 250

 42 CrMo 4

 58 - 62 HRC

 $F_{max} = 600 \text{ kN/m}$

 Operator side

 Head supported

 48.3 kg/m

 Hydraulic clamping

 98.0 mm

 Ex stock / 24 h

 BOS No. BY1C012

Standard length	Part number
515 mm	65206.0004.5007
1030 mm	65206.0004.3009
1000 mm sect. FSC	65206.0004.0004
550 mm sect. FSW	65206.0004.9002
Horn set LH + RH	65206.0004.7003

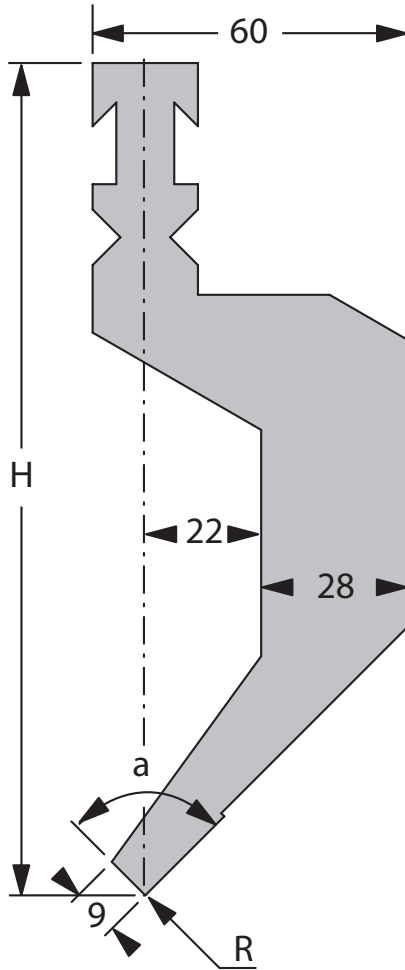

P4 RF-A / 85
 $F = 600 \text{ kN/m}$
 $R = 1.5 / 1 \text{ mm}$
 $H = 250 \text{ mm}$

P5 RF-A H175



[R] Radius (mm) 1

Nose angle 30°

[H] Height (mm) 175

 42 CrMo 4

 58 - 62 HRC

 F_{max} = 1000 kN/m

 Operator side

 Head supported

 19 kg/m

 Hydraulic clamping

 45.5 mm

 Ex stock / 24 h

 BOS No. BY1C019

Standard length	Part number
515 mm	65206.0005.5007
1030 mm	65206.0005.3004
1000 mm sect. FSC	65206.0005.0003
550 mm sect. FSW	65206.0005.9001
Horn set LH + RH	65206.0005.7002

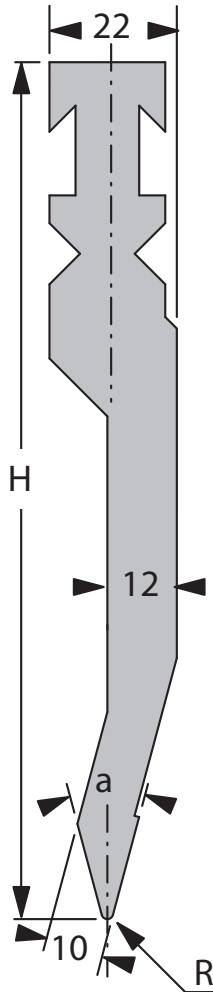

P5 RF-A / 30°
F = 1000 kN/m
R = 1 mm
H = 175 mm

P5 RF-A H250



[R] Radius (mm) 1

Nose angle 30°

[H] Height (mm) 250

 42 CrMo 4

 58 - 62 HRC

 $F_{max} = 750 \text{ kN/m}$

 Operator side

 Head supported

 26 kg/m

 Hydraulic clamping

 98.0 mm

 Ex stock / 24 h

 BOS No. BY1C020

Standard length	Part number
515 mm	65206.0005.5008
1030 mm	65206.0005.3005
1000 mm sect. FSC	65206.0005.0004
550 mm sect. FSW	65206.0005.9002
Horn set LH + RH	65206.0005.7001

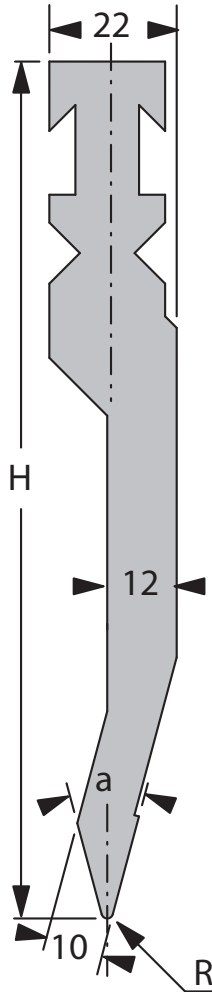

P5 RF-A / 30°
F = 750 kN/m
R = 1 mm
H = 250 mm

P6 RF-A H175



[R] Radius (mm) 1

Nose angle 30°

[H] Height (mm) 175

 42 CrMo 4

 58 - 62 HRC

 F_{max} = 1500 kN/m

 Operator side

 Head supported

 23.3 kg/m

 Hydraulic clamping

 45.5 mm

 Ex stock / 24 h

 BOS No. BY1C023

Standard length	Part number
515 mm	65206.0006.5001
1030 mm	65206.0006.3003
1000 mm sect. FSC	65206.0006.0001
550 mm sect. FSW	65206.0006.9001
Horn set LH + RH	65203.0006.7002

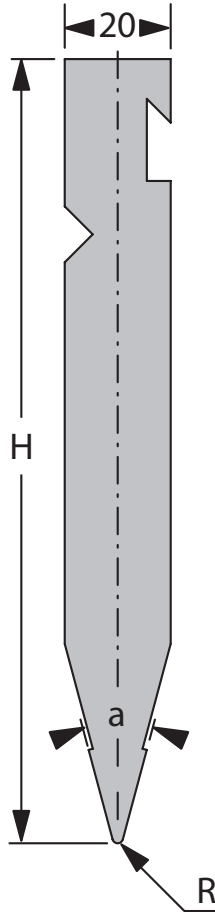

P6 RF-A / 30°
F = 1500 kN/m
R = 1 mm
H = 175 mm

P6 RF-A H250



[R] Radius (mm) 1

Nose angle 30°

[H] Height (mm) 250

 42 CrMo 4

 58 - 62 HRC

 $F_{max} = 1400 \text{ kN/m}$

 Operator side

 Head supported

 35 kg/m

 Hydraulic clamping

 98.0 mm

 Ex stock / 24 h

 BOS No. BY1C024

Standard length	Part number
515 mm	65206.0006.5002
1030 mm	65206.0006.3002
1000 mm sect. FSC	65206.0006.0002
550 mm sect. FSW	65206.0006.9002
Horn set LH + RH	65206.0006.7001

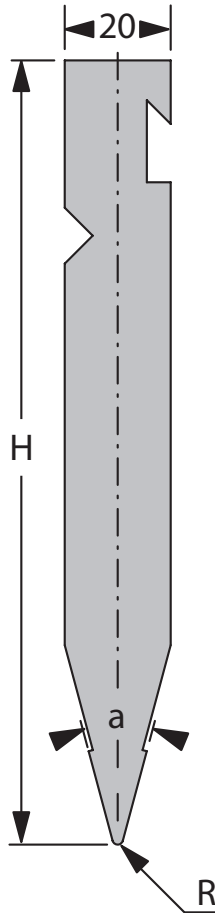

P6 RF-A / 30°
 $F = 1400$ kN/m
 $R = 1$ mm
 $H = 250$ mm

P7 RF-A H175



[R] Radius (mm) 3

Nose angle 30°

[H] Height (mm) 175

 42 CrMo 4

 58 - 62 HRC

 Fmax = 1600 kN/m

 Operator side

 Head supported

 24.2 kg/m

 Hydraulic clamping

 45.5 mm

 Ex stock / 24 h

 BY1C027

Standard length	Part number
515 mm	65206.0007.5002
1030 mm	65206.0007.3004
1000 mm sect. FSC	65206.0007.0003
550 mm sect. FSW	65206.0007.9001
Horn set LH + RH	65206.0007.7001

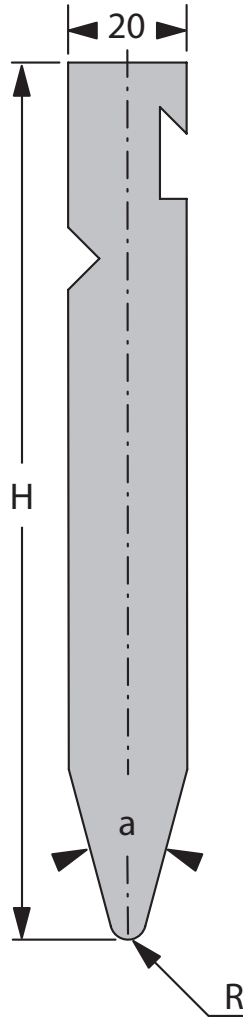

P7 RF-A / 30°
F = 1600 kN/m
R = 3 mm
H = 175 mm

P7 RF-A H250



[R] Radius (mm) 3

Nose angle 30°

[H] Height (mm) 250

 42 CrMo 4

 58 - 62 HRC

 Fmax = 1400 kN/m

 Operator side

 Head supported

 35.9 kg/m

 Hydraulic clamping

 98.0 mm

 Ex stock / 24 h

 BY1C028

Standard length	Part number
515 mm	65206.0007.5003
1030 mm	65206.0007.3006
1000 mm sect. FSC	65206.0007.0002
550 mm sect. FSW	65206.0007.9002
Horn set LH + RH	65206.0007.7002

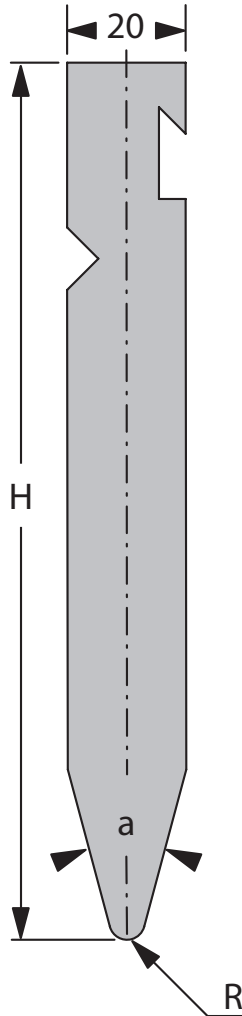

P7 RF-A / 30°
F = 1400 kN/m
R = 3 mm
H = 250 mm

P8 RF-A H175



[R] Radius (mm) 1

Nose angle 85°

[H] Height (mm) 175

 42 CrMo 4

 58 - 62 HRC

 F_{max} = 1000 kN/m

 Operator side

 Head supported

 26.5 kg/m

 Hydraulic clamping

 45.5 mm

 Ex stock / 24 h

 BOS No. BY10123

Standard length	Part number
515 mm	65206.0008.5002
1030 mm	65206.0008.3003
1000 mm sect. FSC	65206.0008.0001
550 mm sect. FSW	65206.0008.9001
Horn set LH + RH	65206.0008.7001

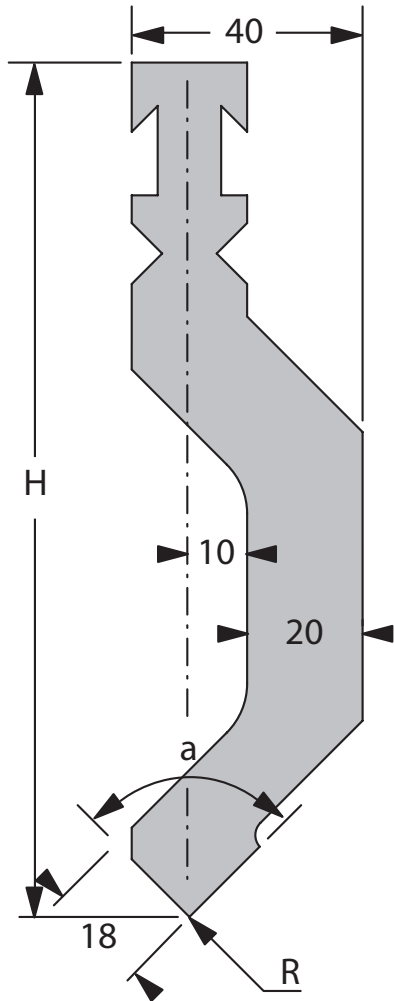

P8 RF-A / 85°
F = 1000 kN/m
R = 1 mm
H = 175 mm

P8 RF-A H250



[R] Radius (mm) 1

Nose angle 85°

[H] Height (mm) 250

 42 CrMo 4

 58 - 62 HRC

 $F_{max} = 1000 \text{ kN/m}$

 Operator side

 Head supported

 38.3 kg/m

 Hydraulic clamping

 98.0 mm

 Ex stock / 24 h

 BOS No. BY1C032

Standard length	Part number
515 mm	65206.0008.5013
1030 mm	65206.0008.3004
1000 mm sect. FSC	65206.0008.0004
550 mm sect. FSW	65206.0008.9002
Horn set LH + RH	65206.0008.7002

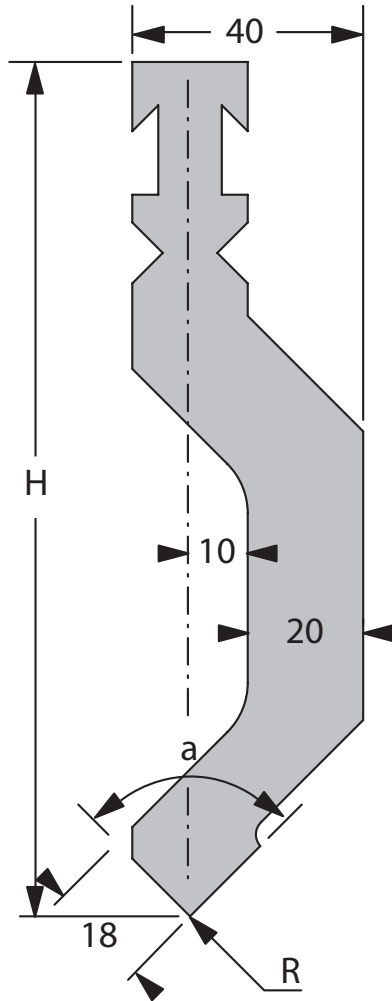

P8 RF-A / 85°
 $F = 1000 \text{ kN/m}$
 $R = 1 \text{ mm}$
 $H = 250 \text{ mm}$

P9 RF-A H175



[R] Radius (mm) 4

Nose angle 60°

[H] High (mm) 175

 42 CrMo 4

 58 - 62 HRC

 Fmax = 1600 kN/m

 Operator side

 Head supported

 33.5 kg/m

 Hydraulic clamping

 45.5 mm

 Ex stock / 24 h

 BOS No. BY1C039

Standardlänge	Part number
515 mm	65206.0009.5006
1030 mm	65206.0009.3003
1000 mm sect. FSC	65206.0009.0001
550 mm sect. FSW	65206.0009.9001
Horn set LH + RH	65206.0009.7001

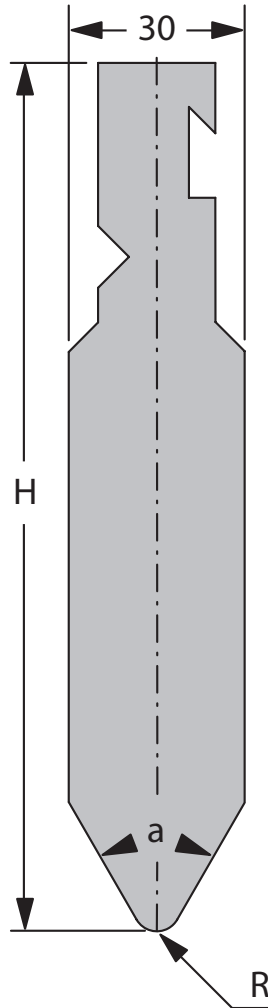

P9 RF-A / 60°
 $F = 1600 \text{ kN/m}$
 $R = 4 \text{ mm}$
 $H = 175 \text{ mm}$

P9 RF-A H250



[R] Radius (mm) 4

Nose angle 60°

[H] Height (mm) 250

 42 CrMo 4

 58 - 62 HRC

 F_{max} = 1600 kN/m

 Operator side

 Head supported

 51 kg/m

 Hydraulic clamping

 98.0 mm

 Ex Stock / 24 h

 BOS No. BY1C040

Standard length	Part number
515 mm	65206.0009.5005
1030 mm	65206.0009.3004
1000 mm sect. FSC	65206.0009.0002
550 mm sect. FSW	65206.0009.9002
Horn set LH + RH	65206.0009.7002

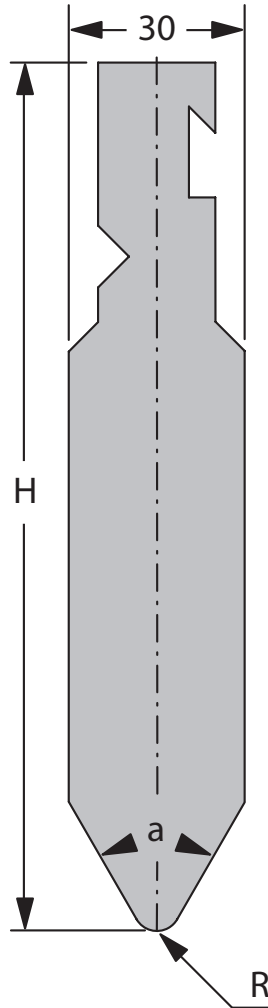

P9 RF-A / 60°
 $F = 1600 \text{ kN/m}$
 $R = 4 \text{ mm}$
 $H = 250 \text{ mm}$

P10 RF-A H150



[R] Radius (mm) -

Nose angle -

[H] Height (mm) 150

 C45

 ---

 $F_{max} = 1600 \text{ kN/m}$

 Operator side

 Head supported

 34 kg/m

 Hydraulic clamping

 ---

 Ex stock / 24 h

 BOS No. BY1C043A

Standard length

Part number

515 mm

65206.0010.5004

1030 mm

65206.0010.3004

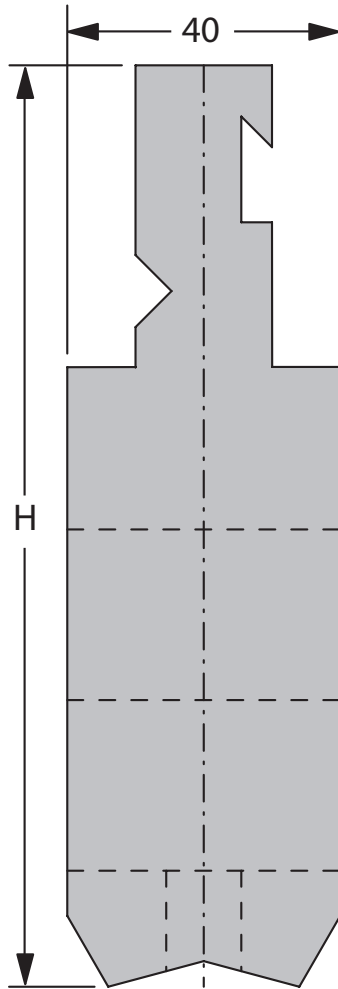

P10 RF-A
F = 1600 kN/m
H = 150 mm

P10 RF-A H250

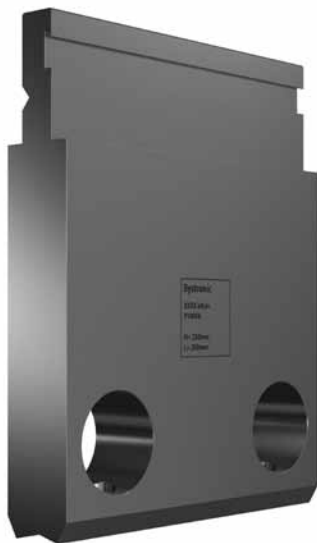

[R] Radius (mm) -

Nose angle -

[H] Height (mm) 250

C45

Fmax = 1600 kN/m

Operator side

Head supported

66 kg

Hydraulic clamping

Ex stock / 24 h

BOS No. BY50026

Standard length	Part number
515 mm	65206.0010.5005
1030 mm	65206.0010.3003

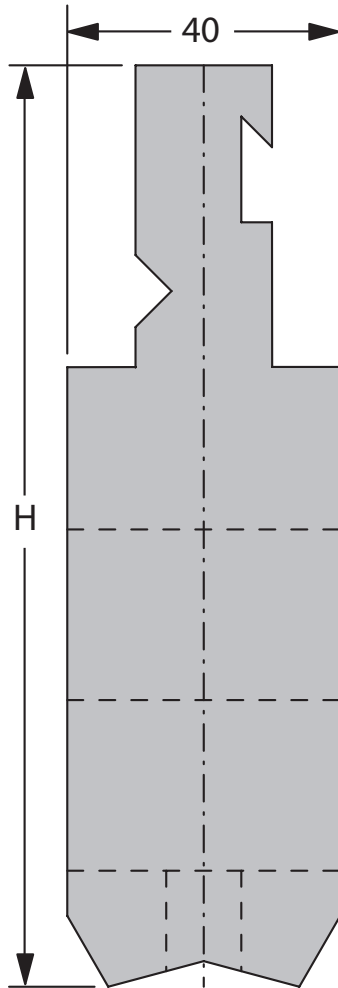

P10 RF-A
F = 1600 kN/m
H = 250 mm

P10 RF-A

Round bars suitable for radius bar holder

Hardened radius bars

L	515/1030	515/1030	515/1030	515/1030	515/1030	515/1030
Type	PB 28	PB 30	PB 35	PB 40	PB 45	PB 50
Ø mm	28	30	35	40	45	50
G	5	5.5	7.5	10	12.5	15.5

515/1030	515/1030	515/1030	515/1030	515/1030
PB 55	PB 60	PB 65	PB 70	PB 80
55	60	65	70	80
18.5	22	26	30	39.5

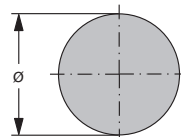

42CrMo4/60 - 62 HRC

Non hardened radius bars of C45 steel (ground) are also available.

P10 RF-A

Round bars suitable for radius bar holder

Length	Ø Round bars	Part number
515 mm	28 mm	65200.0028.5002
	30 mm	65200.0030.5007
	35 mm	65200.0035.5005
	40 mm	65200.0040.5005
	45 mm	65200.0045.5003
	50 mm	65200.0050.5009
	55 mm	65200.0055.5002
	60 mm	65200.0060.5004
	65 mm	65200.0065.5002
	70 mm	65200.0070.5001
80 mm	65200.0080.5003	

1030 mm	28 mm	65200.0028.3002
	30 mm	65200.0030.3007
	35 mm	65200.0035.3002
	40 mm	65200.0040.3006
	45 mm	65200.0045.3002
	50 mm	65200.0050.3005
	55 mm	65200.0055.3001
	60 mm	65200.0060.3004
	65 mm	65200.0065.3001
	70 mm	65200.0070.3003
80 mm	65200.0080.3004	

P11 RF-A H175



[R] Radius (mm) -

Nose angle -

[H] Height (mm) 175

 42 CrMo 4

 58 - 62 HRC

 $F_{max} = 1600 \text{ kN/m}$

 Operator side

 Head supported

 26.7 kg/m

 Hydraulic clamping

 ---

 Ex stock / 24 h

 BOS No. BY1C057

Standard length	Part number
515 mm	65206.0011.5004
1030 mm	65206.0011.3001
1000 mm sect.	65206.0011.0002

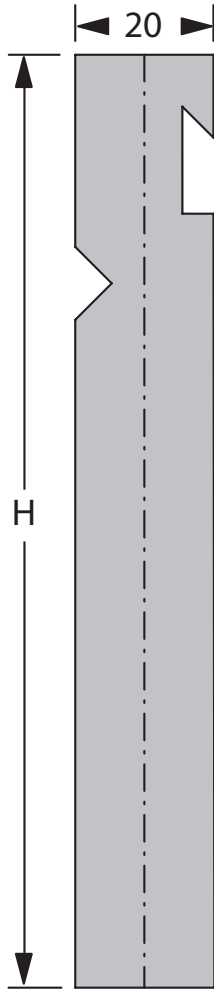

P11 RF-A
F = 1600 kN/m
H = 175 mm

P11 RF-A H250



[R] Radius (mm) -

Nose angle -

[H] Height (mm) 250

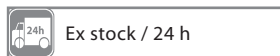
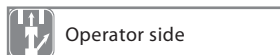
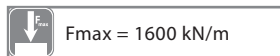
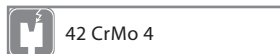

Standard length	Part number
515 mm	65206.0011.5003
1030 mm	65206.0011.3002
1000 mm sect. FSC	65206.0011.0001

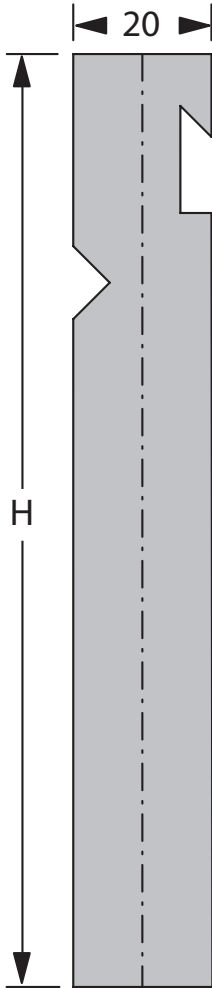

P11 RF-A
F = 1600 kN/m
H = 250 mm

P12 RF-A H130



[R] Radius (mm) -

Nose angle -

[H] Height (mm) 130

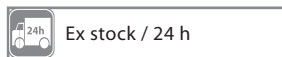
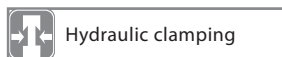
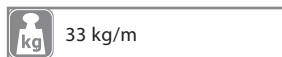
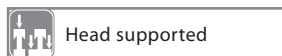
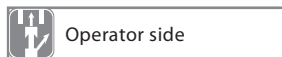

Standard length	Part number
515 mm	65206.0012.5001
1030 mm	65206.0012.3002
1000 mm sect. FSC	65206.0012.0002
550 mm sect. FSW*	65206.0012.9001

*550mm FSW without horns

$H1 = 44 \text{ mm}$
 $H2 = 35 \text{ mm}$
(standard)

P12 RF-A
 $F = 1600 \text{ kN/m}$
 $H = 130 \text{ mm}$

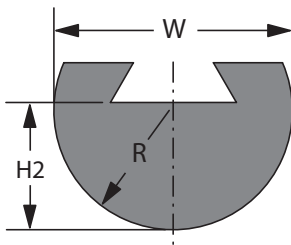

Typ B

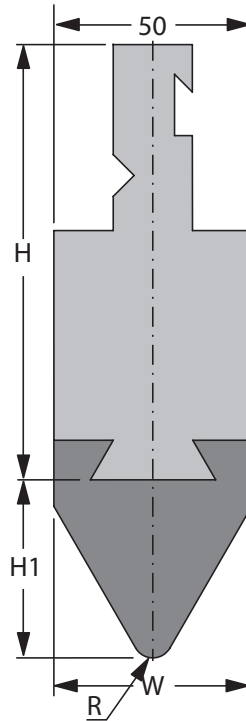

Typ A

P12 Radius tools

42CrMo4 hardened

Radius	Weight	Length	Part number	
R= 5	Type A	6,6 kg	515 mm	65200.0005.5002
		13,1 kg	1030 mm	65200.0005.3002
		12,7 kg	1000 mm SECT. FSC	65200.0005.0002
		7,2 kg	550 mm SECT. FSW	65200.0005.9001
R= 6	Type A	6,6 kg	515 mm	65200.0006.5005
		13,1 kg	1030 mm	65200.0006.3003
		12,7 kg	1000 mm SECT. FSC	65200.0006.0002
		6,9 kg	550 mm SECT. FSW	65200.0006.9001
R= 8	Type A	6,6 kg	515 mm	65200.0008.5003
		13,1 kg	1030 mm	65200.0008.3002
		12,7 kg	1000 mm SECT. FSC	65200.0008.0003
		7,4 kg	550 mm SECT. FSW	65200.0008.9001
R= 10	Type A	6,6 kg	515 mm	65200.0010.5004
		13,1 kg	1030 mm	65200.0010.3002
		12,7 kg	1000 mm SECT. FSC	65200.0010.0003
		7,7 kg	550 mm SECT. FSW	65200.0010.9001
R= 12	Type A	6,6 kg	515 mm	65200.0012.5005
		13,1 kg	1030 mm	65200.0012.3002
		12,7 kg	1000 mm SECT. FSC	65200.0012.0001
		7,9 kg	550 mm SECT. FSW	65200.0012.9001
R= 15	Type A	6,6 kg	515 mm	65200.0015.5002
		13,1 kg	1030 mm	65200.0015.3002
		12,7 kg	1000 mm SECT. FSC	65200.0015.0003
		8,4 kg	550 mm SECT. FSW	65200.0015.9001
R= 20	Type A	6,6 kg	515 mm	65200.0020.5004
		13,1 kg	1030 mm	65200.0020.3005
		12,7 kg	1000 mm SECT. FSC	65200.0020.0001
		8,9 kg	550 mm SECT. FSW	65200.0020.9001
R= 25	Type B	6,6 kg	515 mm	65200.0025.5005
		13,1 kg	1030 mm	65200.0025.3002
		12,7 kg	1000 mm SECT. FSC	65200.0025.0001
		7,4 kg	550 mm SECT. FSW	65200.0025.9001
R= 30	Type B	6,6 kg	515 mm	65200.0030.5004
		13,1 kg	1030 mm	65200.0030.3006
		12,7 kg	1000 mm SECT. FSC	65200.0030.0002
		8,6 kg	550 mm SECT. FSW	65200.0030.9001
R= 35	Type B	6,6 kg	515 mm	65200.0035.5003
		13,1 kg	1030 mm	65200.0035.3001
		12,7 kg	1000 mm SECT. FSC	65200.0035.0001
		10,1 kg	550 mm SECT. FSW	65200.0035.9001

P13 RF-A



[R] Radius (mm) -

Nose angle -

[H] Height (mm)



42 CrMo 4



58 - 62 HRC



F_{max} = 1000 kN/m



Operator side



Head supported



kg/m



Hydraulic clamping



Variable (Edge)



Ex stock / 24 h



IB00674E

Combination between

Hämmerle + Xpert tools

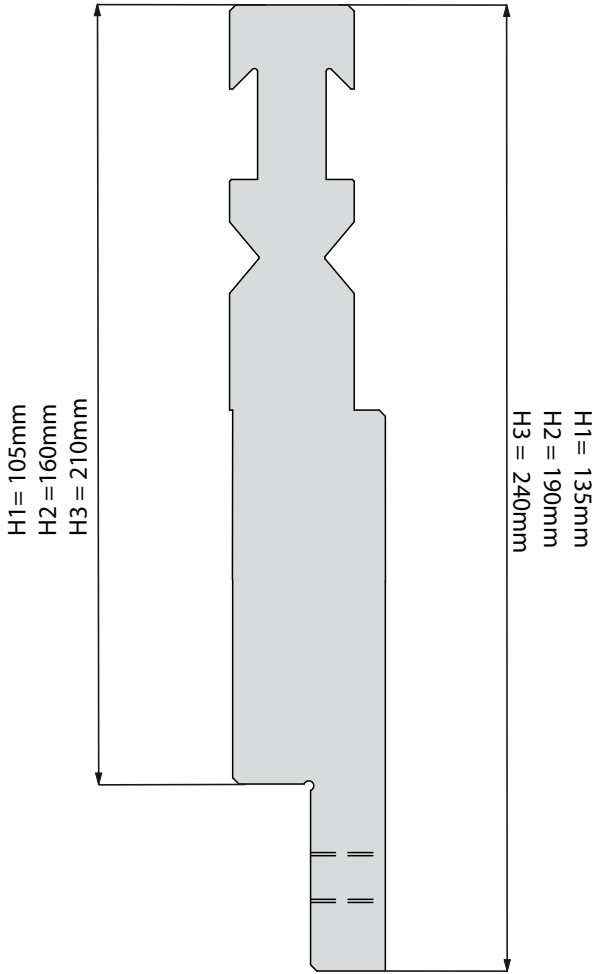

P13 RF-A

Overview

Model	Length	Part number
P13 RFA H1/ IB00674D	50 mm	65206.0013.5001
	55 mm	65206.0013.5002
	60 mm	65206.0013.5003
	65mm	65206.0013.5004
	Horn 70mm	65206.0013.5005
	80 mm	65206.0013.5006
	85 mm	65206.0013.5007
	90 mm	65206.0013.5008
	95 mm	65206.0013.5009
	100 mm	65206.0013.5010
	200 mm	65206.0013.5011
	500 mm	65206.0013.5012
	1000 mm sect.	65206.0013.0001
75 mm	65206.0013.5039	

1000 sect. = 50mm, 55mm, 60mm, 2x 65mm, 70mm Horn, 80mm, 90mm, 95mm, 100mm, 200mm

Model	Length	Part number
P13 RFA H2/ IB00696D	50 mm	65206.0013.5013
	55 mm	65206.0013.5014
	60 mm	65206.0013.5015
	65mm	65206.0013.5016
	Horn 70mm	65206.0013.5017
	80 mm	65206.0013.5018
	85 mm	65206.0013.5019
	90 mm	65206.0013.5020
	95 mm	65206.0013.5021
	100 mm	65206.0013.5022
	200 mm	65206.0013.5023
	500 mm	65206.0013.5024
	1000 mm sect.	65206.0013.0002
75 mm	65206.0013.5038	

1000 sect. = 50mm, 55mm, 60mm, 2x 65mm, 70mm Horn, 80mm, 90mm, 95mm, 100mm, 200mm

P13 RF-A

Overview

Model	Length	Part number
P13 RFA H3/ IB00697F	50 mm	65206.0013.5025
	55 mm	65206.0013.5026
	60 mm	65206.0013.5027
	65mm	65206.0013.5028
	Horn 70mm	65206.0013.5029
	80 mm	65206.0013.5030
	85 mm	65206.0013.5031
	90 mm	65206.0013.5032
	95 mm	65206.0013.5033
	100 mm	65206.0013.5034
	200 mm	65206.0013.5035
	500 mm	65206.0013.5036
	1000 mm sect.	65206.0013.0003
75 mm	65206.0013.5037	

1000 sect. = 50mm, 55mm, 60mm, 2x 65mm, 70mm Horn, 80mm, 90mm, 95mm, 100mm, 200mm

Adapter P25 RF-A/Euro B



[R] Radius (mm) -

Nose angle -

[H] Height (mm) 130/250

Length (mm) 150

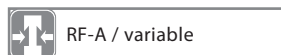
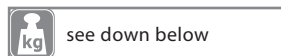
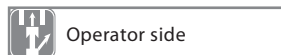
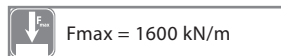

Type	Height (mm)	Weight (kg/ m)	Psrt number
P25 R	105	16	64600.000.0072
P25 RF	130	20	64600.000.0072
P25 RF	200	31	64600.000.0073
P25 RF-A	130	20	64600.000.0033
P25 RF- A	250	38.8	64600.000.0037

Example: R / Euro B

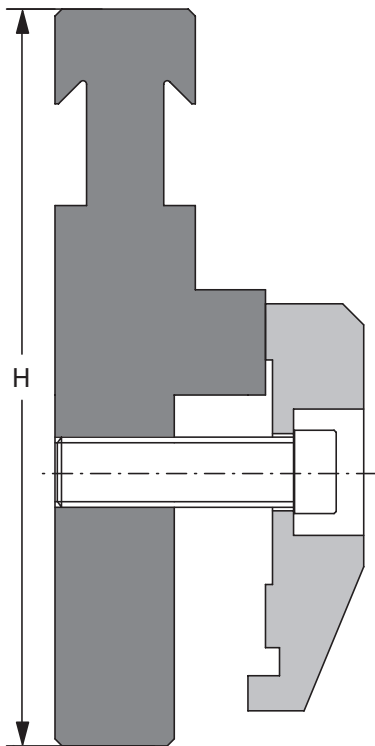

Extension P30



[R] Radius (mm) -

Nose angle -

[H] Height (mm) variable

Length (mm) 150

 C45

 ---

 Fmax = 1600 kN/m

 Operator side

 Head supported

 see down below

 Xpert / variable

 ---

 Ex stock / 24 h

 ---

Type	High H / H1 in mm	Weight in kg / m	Part number
P30 R	139/100	43	64600.0000.0025
P30 RF	184/125	46.9	64600.0000.0049
P30 RF	259/200	58.7	64600.0000.0039
P30 RF-A	184/125	46.9	64600.0000.0024
P30 RF-A	309/250	66.5	64600.0000.0032

Example: RF-A / RF

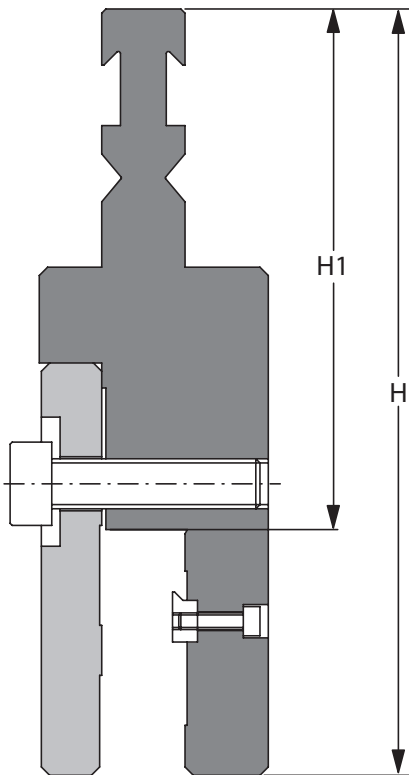

Notes

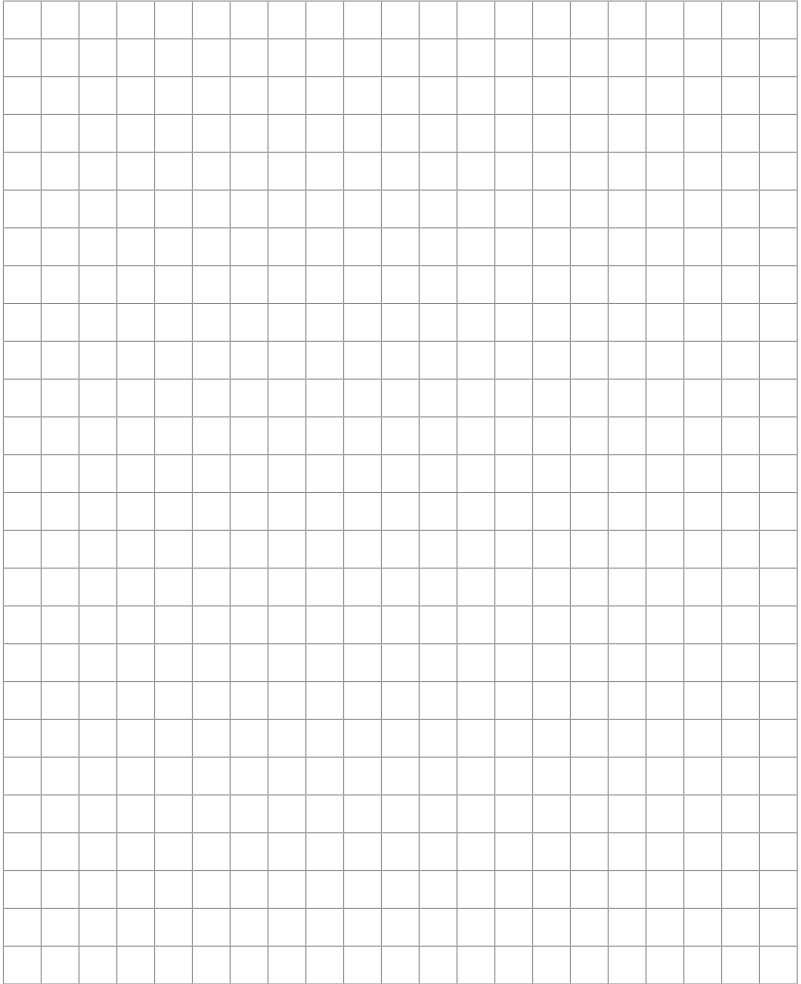

Bottom tools



Lower table options

Tables with mechanical tool clamping

T5
(Standard Xpert 60 – 320)

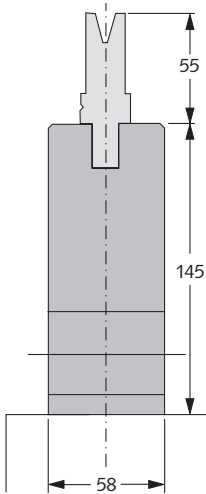

Fitting bottom tools
up to V80.

T55
(Standard Xpert 250 – 1000)

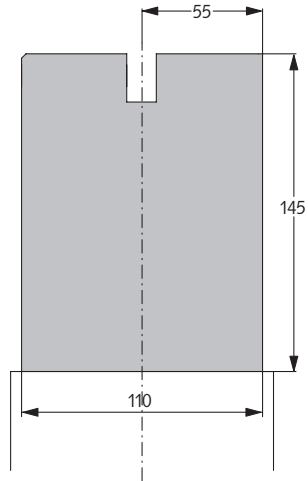

Fitting bottom tools
up to V150.

Lower table options

Table with hydraulic tool clamping

T12

(Optional Xpert 60 - 320 and
Xpert 250 - 1000)

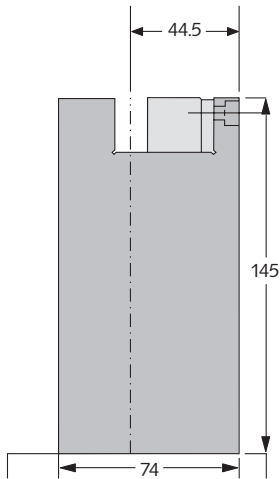

Fitting bottom tools
up to V80.

T13

(Optional Xpert 60 - 320 and
Xpert 250 - 1000)

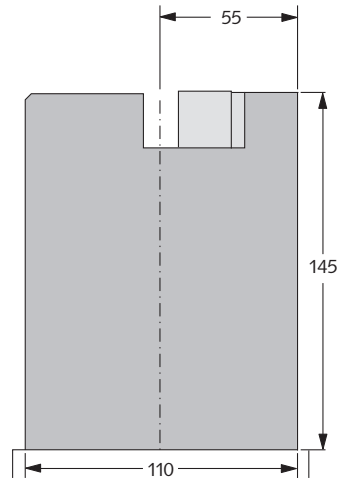

Fitting bottom tools
up to V150.

Lower table options

Tables for larger bottom tools

T2

(Standard Xpert MAMMUT and
Optional Xpert 250 - 1000)*

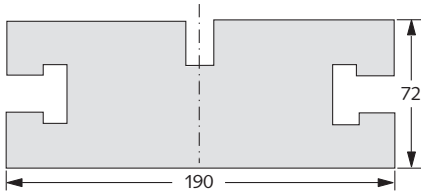

Fitting bottom tools
up to V250.

* this table is ideal to use adapter's (for example S1),
large bottom tools or with V bottom tools.

Lower table options

Hydraulic hemming table with hydraulic die clamping

T9

(Optional for Xpert 60 - 320)

up to 2mm material thickness

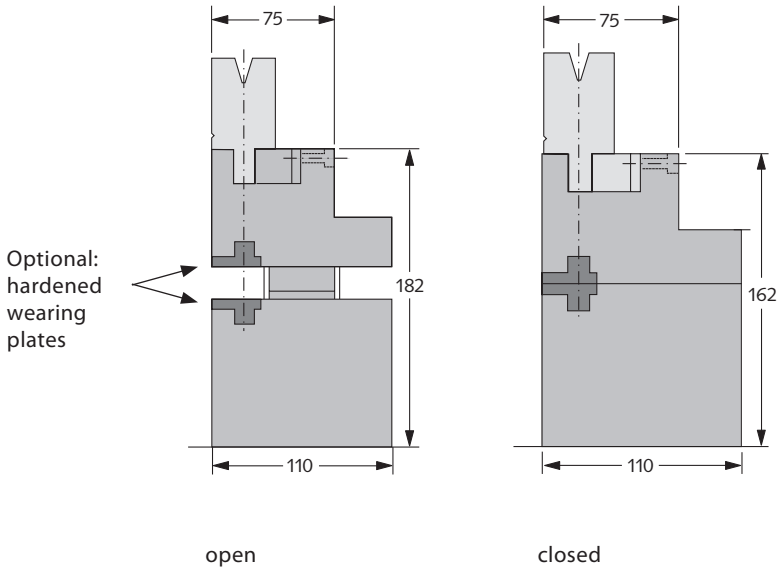

Fitting bottom tools up to V60.

This table combines the high productivity of the hydraulic tool clamping with the flexibility of hemming.

Segmentation of bottom tools

Segmentation FSC/1000 mm

(10 + 15 + 20 + 30 + 50 + 100 + 200 + 275 + 300)



10	15	20	30	50	100	200	275	300
----	----	----	----	----	-----	-----	-----	-----

FSW/550 mm

(20 + 25 + 30 + 35 + 40 + 200 + 2x100)

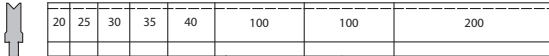

20	25	30	35	40	100	100	200
----	----	----	----	----	-----	-----	-----

Special segmentation on request.

In addition all lower dies can be supplied with modified radii, die angle and height (non standard).

Notes



V6/30°

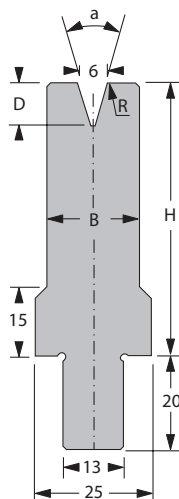

[R] Radius (mm) 0.75

[a] V - Angle 30°

[H] Height (mm) 55

[B] Width (mm) 20

[D] Depth (mm) 9.3

Weight / Meter 10.9 Kg

Standard length	Part number
515 mm	64201.0006.5004
1030 mm	64201.0006.3008
1000 mm sect. FSC	64201.0006.0001
550 mm sect. FSW	64201.0006.9001

 42 CrMo 4

 58 - 62 HRC

 F max 30° = 400 kN/m

 F max 90° = 800 kN/m

 Die insert 13 mm

 Ex stock / 24 h

 BOS No. BY2C001

V8/30°

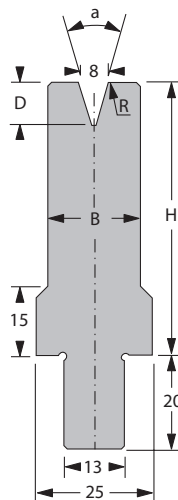



[R] Radius (mm)	1
[a] V - Angle	30°
[H] Height (mm)	55
[B] Width (mm)	20
[D] Depth(mm)	11.2
Weight / Meter	10.8 Kg

Standard length	Part number
515 mm	64201.0008.5012
1030 mm	64201.0008.3005
1000 mm sect. FSC	64201.0008.0001
550 mm sect. FSW	64201.0008.9001

 42 CrMo 4

 58 - 62 HRC

 F max 30° = 300 kN/m

 F max 90° = 1000 kN/m

 Sie insert 13 mm

 Ex Stock / 24 h

 BOS No. BY2C007

V10/30°



[R] Radius (mm)	1
[a] V - Angle	30°
[H] Height (mm)	55
[B] Width (mm)	20
[D] Depth (mm)	14.9
Weight / Meter	10.6 Kg

Standard length	Part number
515 mm	64201.0010.5016
1030 mm	64201.0010.3006
1000 mm sect. FSC	64201.0010.0004
550 mm sect. FSW	64201.0010.9001

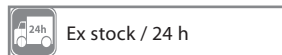
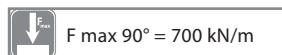
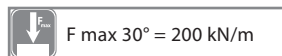
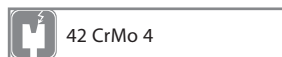
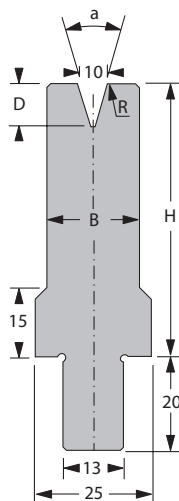

V12/30°



[R] Radius (mm)	1.5
[a] V - Angle	30°
[H] Height (mm)	55
[B] Width (mm)	25
[D] Depth (mm)	18.6
Weight / Meter	11.8 Kg

Standard length	Part number
515 mm	64201.0012.5007
1030 mm	64201.0012.3009
1000 mm sect. FSC	64201.0012.0002
550 mm sect. FSW	64201.0012.9001

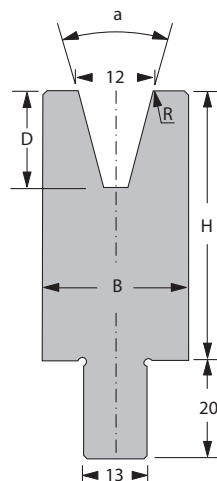

 42 CrMo 4

 58 - 62 HRC

 F max 30° = 250 kN/m

 F max 90° = 900 kN/m

 Die insert 13 mm

 Ex stock / 24 h

 BOS No. BY2C016A

V16/30°

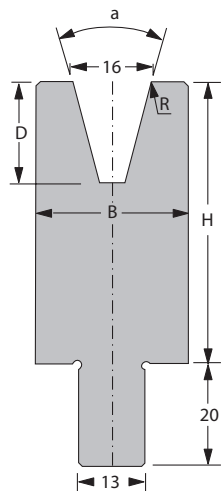

[R] Radius (mm)	2
[a] V - Angle	30°
[H] Height (mm)	55
[B] Width (mm)	30
[D] Depth (mm)	20.5
Weight / Meter	13.3 Kg

Standard length	Part number
515 mm	64201.0016.5011
1030 mm	64201.0016.3006
1000 mm sect. FSC	64201.0016.0001
550 mm sect. FSW	64201.0016.9001

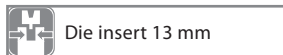
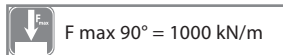
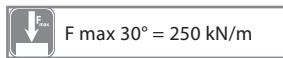
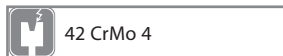

V20/30°

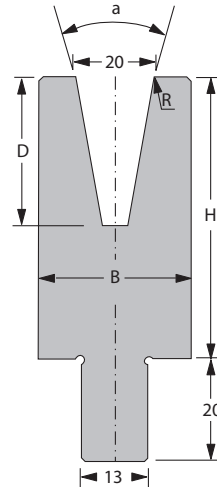



[R] Radius (mm)	2.5
[a] V - Angle	30°
[H] Height (mm)	55
[B] Width (mm)	30
[D] Depth (mm)	28
Weight / Meter	12.2 Kg

Standard length	Part number
515 mm	64201.0020.5002
1030 mm	64201.0020.3007
1000 mm sect. FSC	64201.0020.0002
550 mm sect. FSW	64201.0020.9001

 42 CrMo 4

 58 - 62 HRC

 F max 30° = 150 kN/m

 F max 90° = 600 kN/m

 Die insert 13 mm

 Ex stock / 24 h

 BOS No. BY20002

V24/30°

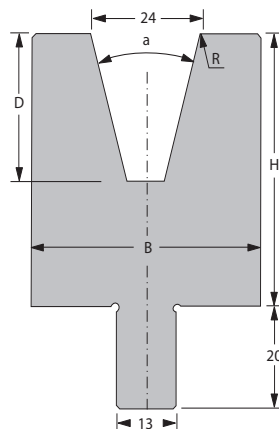

[R] Radius (mm)	3
[a] V - Angle	30°
[H] Height (mm)	55
[B] Width (mm)	40
[D] Depth (mm)	29.8
Weight / Meter	15.5 Kg

Standard length	Part number
515 mm	64201.0024.5010
1030 mm	64201.0024.3005
1000 mm sect. FSC	64201.0024.0001
550 mm sect. FSW	64201.0024.9001

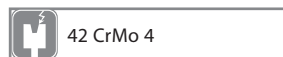

42 CrMo 4



58 - 62 HRC

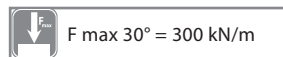

F max 30° = 300 kN/m

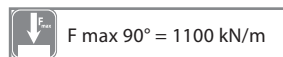

F max 90° = 1100 kN/m



Die insert 13 mm

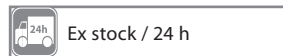

Ex stock / 24 h

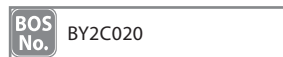

BOS No. BY2C020

V32/30° *

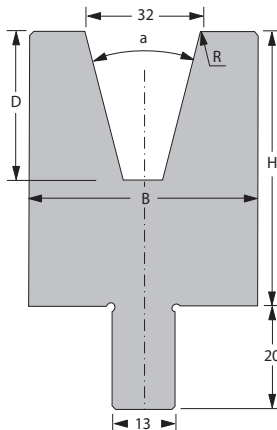

[R] Radius (mm)	4
[a] V - Angle	30°
[H] Height (mm)	55
[B] Width (mm)	48
[D] Depth (mm)	33.6
Weight / Meter	16.7 Kg

Standard length	Part number
515 mm	64201.0032.5010
1030 mm	64201.0032.3006
1000 mm sect. FSC	64201.0032.0002
550 mm sect. FSW	64201.0032.9001

* Also available with rolls.

42 CrMo 4

58 - 62 HRC

F max 30° = 300 kN/m

F max 90° = 1100 kN/m

Die insert 13 mm

Ex stock / 24 h

BOS No. BY2C021

V40/60° *

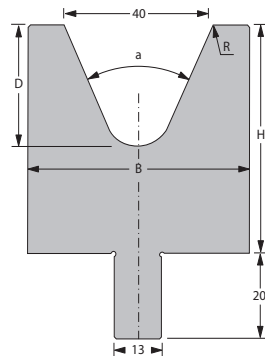

[R] Radius (mm)	5
[a] V - Angle	60°
[H] Height (mm)	55
[B] Width (mm)	55
[D] Depth (mm)	29.6
Weight / Meter	20.5 Kg

Standard length	Part number
515 mm	64201.0040.5003
1030 mm	64201.0040.3007
1000 mm sect. FSC	64201.0040.0002
550 mm sect. FSW	64201.0040.9001

* Also available with rolls.

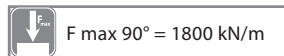
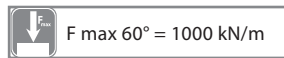
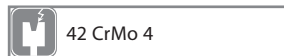

V50/60° *

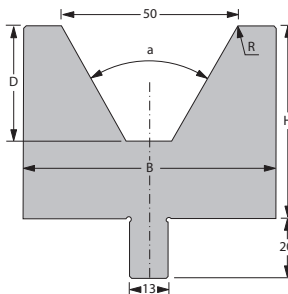

[R] Radius (mm) 5

[a] V - Angle 60°

[H] Height (mm) 55

[B] Width (mm) 70

[D] Depth (mm) 30.3

Weight / Meter 24.5 Kg

Standard length	Part number
515 mm	64201.0050.5003
1030 mm	64201.0050.3003
1000 mm sect. FSC	64201.0050.0001
550 mm sect. FSW	64201.0050.9001

 42 CrMo 4

 58 - 62 HRC

 F max 60° = 1000 kN/m

 F max 90° = 1800 kN/m

 Die insert 13 mm

 Ex stock / 24 h

 BOS No. BY2C022

* Also available with rolls.

V60/60° *

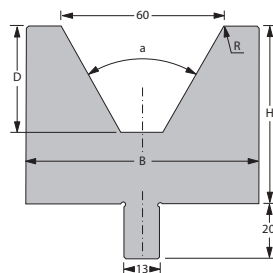

[R] Radius (mm)	7
[a] V - Angle	60°
[H] Height (mm)	65
[B] Width (mm)	80
[D] Depth (mm)	39
Weight / Meter	31.4 Kg

Standard length	Part number
515 mm	64201.0060.5005
1030 mm	64201.0060.3005
1000 mm sect. FSC	64201.0060.0002
550 mm sect. FSW	64201.0060.9001

* Also available with rolls.

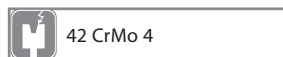

42 CrMo 4



58 - 62 HRC

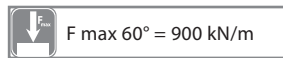

F max 60° = 900 kN/m

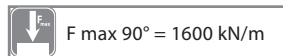

F max 90° = 1600 kN/m



Die insert 13 mm

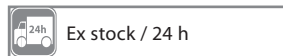

Ex stock / 24 h



BOS No. BY2C024

V80/80° *

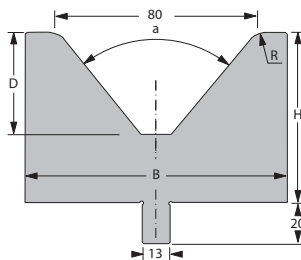

[R] Radius (mm)	10
[a] V - Angle	80°
[H] Height (mm)	65
[B] Width (mm)	100
[D] Depth (mm)	38.7
Weight / Meter	38.6 Kg

Standard length	Part number
515 mm	64201.0080.5002
1030 mm	64201.0080.3005
1000 mm sect. FSC	64201.0080.0001
550 mm sect. FSW	64201.0080.9001

* Also available with rolls.

42 CrMo 4

58 - 62 HRC

F max 80° = 1400 kN/m

F max 90° = 1600 kN/m

Die insert 13 mm

Ex stock / 24 h

BOS No. BY2C025

V100/80° *

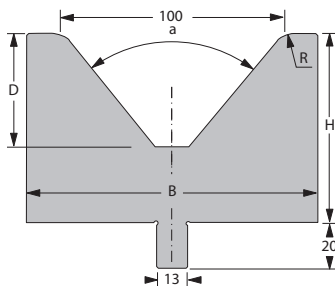

[R] Radius (mm)	12
[a] V - Angle	80°
[H] Height (mm)	85
[B] Width (mm)	125
[D] Depth (mm)	50.5
Weight / Meter	62.5 Kg

Standard length	Part number
515 mm	64201.0100.5004
1030 mm	64201.0100.3005
1000 mm sect. FSC	64201.0100.0001
550 mm sect. FSW	64201.0100.9001

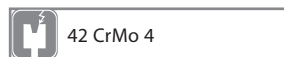

42 CrMo 4



58 - 62 HRC

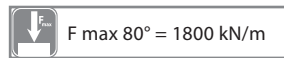

F max 80° = 1800 kN/m

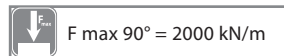

F max 90° = 2000 kN/m



Die insert 13 mm



Ex stock / 24 h



BOS No. BY2C026

* Also available with rolls.

V120/80° *

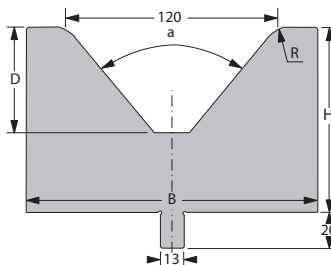



[R] Radius (mm)	15
[a] V - Angle	80°
[H] Height (mm)	105
[B] Width (mm)	160
[D] Depth (mm)	59.5
Weight / Meter	101 Kg

Standard length	Part number
515 mm	64201.0120.5002
1030 mm	64201.0120.3004
1000 mm sect. FSC	64201.0120.0001
550 mm sect. FSW	64201.0120.9001

 42 CrMo 4

 58 - 62 HRC

 F max 80° = 2000 kN/m

 F max 90° = 2400 kN/m

 Die insert 13 mm

 Ex stock / 24 h

 BOS No. BY2C027

* Also available with rolls.

S1/73

100

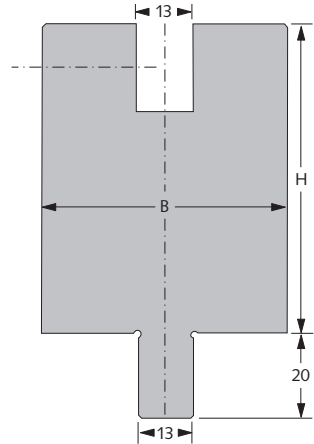

[R] Radius (mm)	-
V - Angle	-
[H] Height (mm)	73
[B] Width (mm)	58
[D] Depth (mm)	22
Weight / Meter	33 Kg

Standard length	Part number
515 mm	64201.0001.5008
1030 mm	64201.0001.3003
1000 mm sect. FSC	64201.0001.0003
550 mm sect. FSW	64201.0001.9001

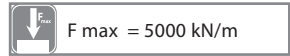

S1/100

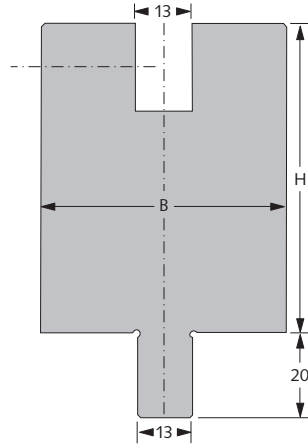

[R] Radius (mm)	-
V - Angle	-
[H] Height (mm)	100
[B] Width (mm)	58
[D] Depth (mm)	22
Weight / Meter	45.3 Kg

Standard length	Part number
515 mm	64201.0001.5006
1030 mm	64201.0001.3004
1000 mm sect. FSC	64201.0001.0001
550 mm sect. FSW	64201.0001.9002

C45

F max = 5000 kN/m

Die insert 13 mm

Ex stock / 24 h

BY40003

Hemming tools air bending

Hemming tool P900 (upper tool)

P900

$L = 515 / 1030$ $S = 1000 / 1100$ $R = 1$ $\alpha = 30^\circ$

	P900 R			P900 RF			P900 RF-A		
H	175			175			175		
B	6	8	10	6	8	10	6	8	10
G	22	22.8	21	24	24.6	25.2	23	24.4	25
F	500	700	1000	500	700	1000	500	700	1000

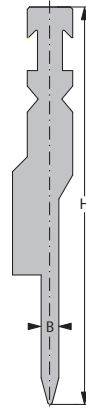

P900 and V900



Material thickness mm	Required press force t/m	C mm	Required press force t/m	D mm
0.6	9	3.0	32	1.2
0.8	13	3.0	34	1.6
1.0	15	3.5	36	2.0
1.2	18	3.5	46	2.4
1.6	24	3.5	48	3.2
2.0	42	4.5	52	4.0

L = length (mm)
 S = sectionalized (mm)
 Z = width (mm)
 R = radius (mm)
 H = Height (mm)
 B = nose width (mm)
 W = die opening (mm)
 G = weight (kg/m)
 F = max. permissible load (kN/m)

Hemming tools air bending

Hemming tool P900 (upper tool)

Mod.	B mm	Z	L mm	Part number
P900.RFA.06	6	14	515	65206.0900.5013
P900.RFA.06	6	14	1030	65206.0900.3004
P900.RFA.06	6	14	1000 S	65206.0900.0010
P900.RFA.08	8	13	515	65206.0900.5005
P900.RFA.08	8	13	1030	65206.0900.3002
P900.RFA.08	8	13	1000 S	65206.0900.0002
P900.RFA.10	10	12	515	65206.0900.5004
P900.RFA.10	10	12	1030	65206.0900.3005
P900.RFA.10	10	12	1000 S	65206.0900.0004
P900.RFA.12	12	11	515	65206.0900.5007
P900.RFA.12	12	11	1030	65206.0900.3003
P900.RFA.12	12	11	1000 S	65206.0900.0003

Loading capacity of the tools (bending forces) P900 + V900:

Pre bending step: 25 t/m

Hemming step: 50 t/m

B= 6 mm -> for sheet thickness up to 1,0 mm

B= 8 mm -> for sheet thickness up to 1,5 mm

B=10 mm -> for sheet thickness up to 2,0 mm

B=12 mm -> for sheet thickness up to 2,3 mm

Hemming tools air bending

Hemming tool V900 (bottom tool)

V900

L = 515 / 1030 S = 1000 / 1100

V900				
H	85			
W	6	8	10	12
G	36.5	37	38	39
F	500			

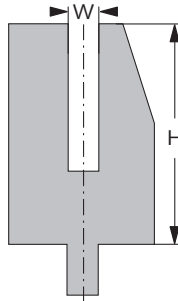

P900 and V900

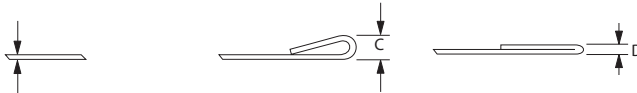

Material thickness mm	Required press force t/m	C mm	Required press force t/m	D mm
0.6	9	3.0	32	1.2
0.8	13	3.0	34	1.6
1.0	15	3.5	36	2.0
1.2	18	3.5	46	2.4
1.6	24	3.5	48	3.2
2.0	42	4.5	52	4.0

L = length (mm)
 S = sectionalized (mm)
 Z = width (mm)
 R = radius (mm)
 H = high (mm)
 B = nose width (mm)
 W = die opening (mm)
 G = weigth (kg/m)
 F = max. permissible load (kN/m)

Hemming tools air bending

Hemming tool V900 (bottom tool)

Mod.	W mm	R mm	L mm	Part number
V900.06	6	1	515	64201.0900.5010
V900.06	6	1	1030	64201.0900.3007
V900.06	6	1	1000 S	64201.0900.0006
V900.08	8	1	515	64201.0900.5005
V900.08	8	1	1030	64201.0900.3003
V900.08	8	1	1000 S	64201.0900.0002
V900.10	10	1	515	64201.0900.5004
V900.10	10	1	1030	64201.0900.3004
V900.10	10	1	1000 S	64201.0900.0004
V900.12	12	1	515	64201.0900.5007
V900.12	12	1	1030	64201.0900.3006
V900.12	12	1	1000 S	64201.0900.0003

Loading capacity of the tools (bending forces) P900 + V900:

Pre bending step: 25 t/m

Hemming step: 50 t/m

B= 6 mm -> for sheet thickness up to 1,0 mm

B= 8 mm -> for sheet thickness up to 1,5 mm

B=10 mm -> for sheet thickness up to 2,0 mm

B=12 mm -> for sheet thickness up to 2,3 mm

Special applications

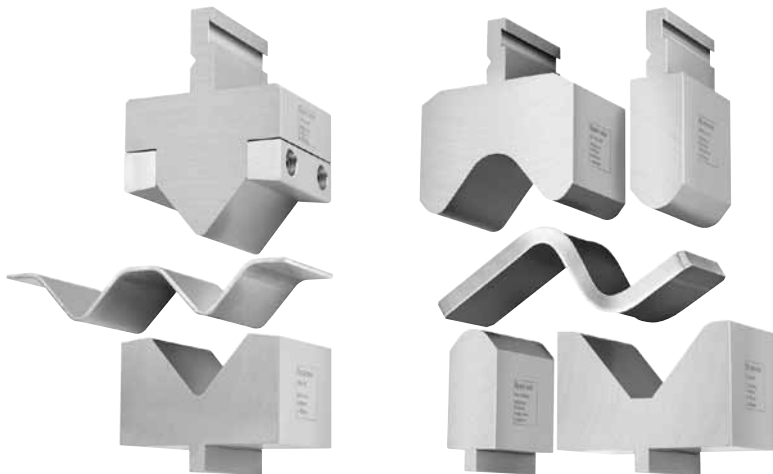

Special tools are also part of the Bystronic tooling range.

Our tooling specialist will help you to solve your forming problems, all contact information are located at the end of the catalog.

Visit our shop in the Internet under: www.bystronic.com

Special applications



Workshop

Taking bending into design

Small bending radii?
Short flange length?
Too much welding, cleaning and flattening?
Bending marks?



What are the topics?

- Basics
- Software presentations
- Machine presentations
- Industrial design expert talks
- Case studies
- Your questions

You can obtain date and further information from our consulting engineers, all contact dates you can be found on the last page.

Further information can be obtained at: www.bystronic.com

Workshop

Bending of high tensile strength materials

109

Material costs are too high?
Wear and tear resistance relevant?
Challenge light construction?
Steel broken yet?



What are the topics?

- Basics
- Experts talks of steel producers
- How the software can help
- Bend case studies
- Specialist talks

You can obtain data and further information from our consulting engineers, all contact data can be found on the last page.

Further information can be obtained at: www.bystronic.com

Bystronic world wide

Bystronic do Brasil Ltda.

Rua Parma 203,
83.413-587 Colombo PR/BR
Brazil

Tel. +55 41 3666 9000
Fax +55 41 3606 8332

Bystronic Canada Ltd.

5730 Coopers Avenue #24
L4Z 2E9 Mississauga

Canada
Tel. +1 905 890 2999
Fax +1 905 890 2998

Bystronic Czech Republic s.r.o.

Turanka 115/1222
627 00 Brno Slatina

Ceská Republika
Tel. +420 532 123 314
Fax +420 532 123 315

Bystronic Co., Ltd (Shanghai)

Level 2, Part A,
No. 999 Huaxu Road Qingpu
China 200702 Shanghai

Tel. +86 21 6082 9300
Fax +86 21 5688 0481

SC Bystronic Laser S.R.L.

Parcu Industrial Pro Roman
Str. Poienilor 5
500419 Brasov

Romania
Tel. +40 268 322140
Fax +40 268 322143

Bystronic Deutschland GmbH

Römerstraße 14
71296 Heimsheim

Deutschland
Tel. +49 7033 4699 0
Fax +49 7033 4699 222

Bystronic Iberica, S.A.

Avenida Tenerife n° 2
Edificio 1, 3a planta, Oficana D
ES-28700 San Sebastián de los
Reyes

Espania
Tel. +34 91 654 48 78
Fax +34 91 652 49 83

Bystronic France S.A.

Park Technopolis,
3 Avenue du Canada
F-91940 Les Ulis

France
Tel. +33 1 69 41 99 84
Fax +33 1 69 41 99 51

Bystronic Laser India (Pvt) Ltd.

7 C, Tadiwala Road
Next to Hotel Panchratna
Pune 411 001

India
Tel. +91 20 67294800
Mobile +91 67294801



Bystronic world wide

Bystronic Italia SRL

Via del Lavoro 30
I-20813 Bovisio Masciago (MB)
Italia

Tel. +39 0362 59 93 1
Fax +39 0362 59 93 209

Bystronic Korea Ltd.

1027-11 Hogye-Dong,
Dongan-Gu,
431-080 Anyang-Si

Korea

Tel. +82 31 389 9800
Fax +82 31 389 9819

Bystronic Mexico S.A. de C.V.

Calle Canes 3250 Int.23,
Col. La Nogalera
44470 Guadalajara

Mexico

Tel. +52 33 3044 0505
Fax +52 33 1380 9979

Bystronic Benelux BV

Stek 8
NL-3371 KG Hardinxveld-
Giessendam

Nederland

Tel. +31 184 611 020
Fax +31 184 617 774

Bystronic Austria GmbH

Salzburger Straße 205
AT-4030 Linz

Österreich

Tel. +43 732 341 155
Fax +43 732 341 153

Bystronic Polska Sp. z o.o

Sekocin Nowy,
Al. Krakowska 81
PL-05-090 Raszyn

Polska

Tel. +48 22 331 378 2
Fax +48 22 331 377 1

OOO Bystronic Laser

Zorge Street, 9A, building 2
125252 Moscow

Russia

Tel. +7 495 984 71 44
Fax +7 495 984 71 47

Bystronic Sales AG

Industriestrasse 21
CH-3362 Niederönz

Schweiz

Tel. +41 62 956 37 38
Fax +41 62 956 33 81

Bystronic PTE LTD

2 Leng Kee Road #03-05
Thye Hong Centre

Singapore

Tel. +65 6472 6300
Fax +65 6472 6032

Bystronic Scandinavia AB

Metallvägen 30 A
SE-195 72 Rosersberg

Sverige

Tel. +46 8 594 415 50
Fax +46 8 594 415 55

Bystronic Lazer

Barbaros Caddesi K:1 No 66
34775 Ümraniye / Istanbul
Turkey

Tel.: +90 216 464 61 60
Fax: +90 216 464 61 11

Bystronic UK Limited

6 Wayside Business Park
Wilson Lane
Coventry CV6 6NY

United Kingdom

Tel. +44 844 848 5850
Fax +44 844 848 5851

Bystronic Inc.

200 Airport Road
60123-932 Elgin IL

USA

Tel. +1 847 214 0300
Fax +1 847 214 0299

Bystronic Intern. Laser Ltd.

Minsheng Rd., Banqiao Dist.
Rm. 1B, 24F-1, No. 33, Sec. 1
220 New Taipei City

Taiwan

Tel. +886 229 599 699
Fax +886 229 599 698

LLC Bystronic Ukraine

Zhylyanska Street 59
Diplomat Hall, OPffice 207
01033 Kiev

Ukraine

Tel. +380 44 569 74 37
Fax +380 44 569 74 38

Notes

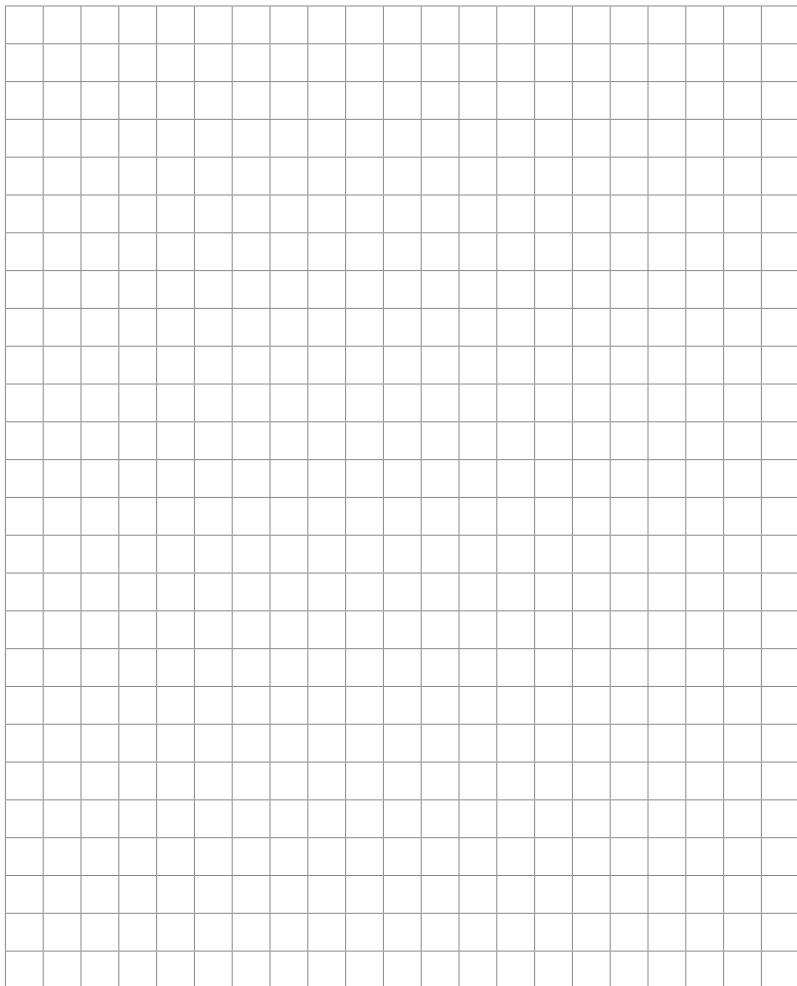

Notes

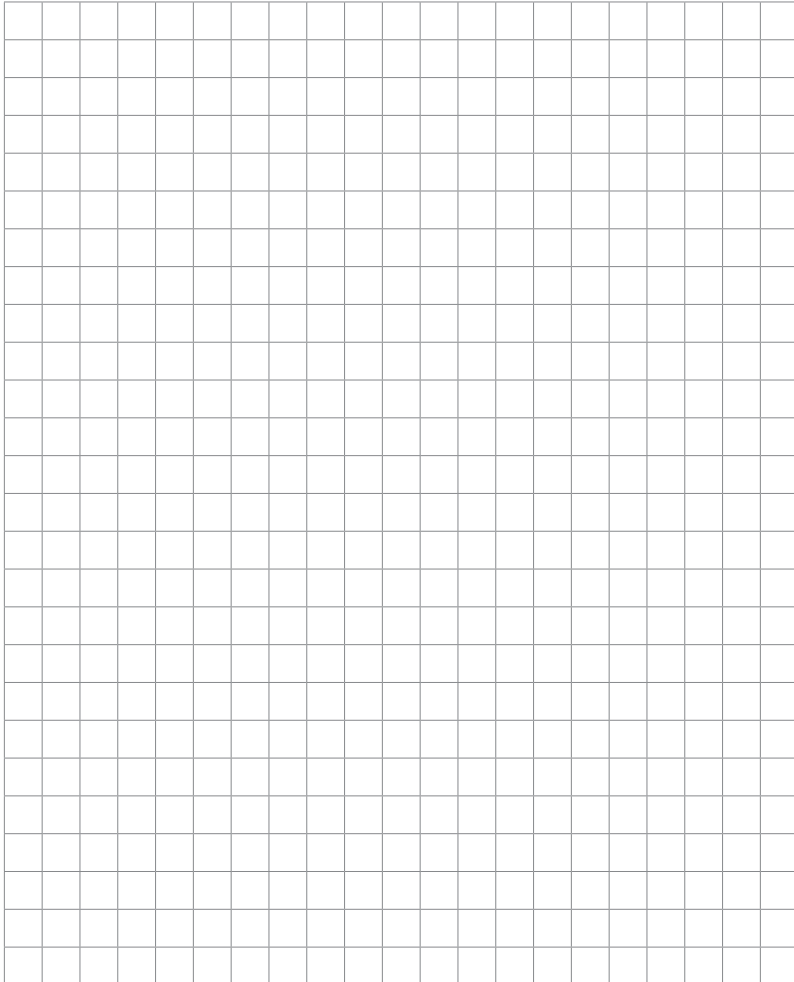

Notes

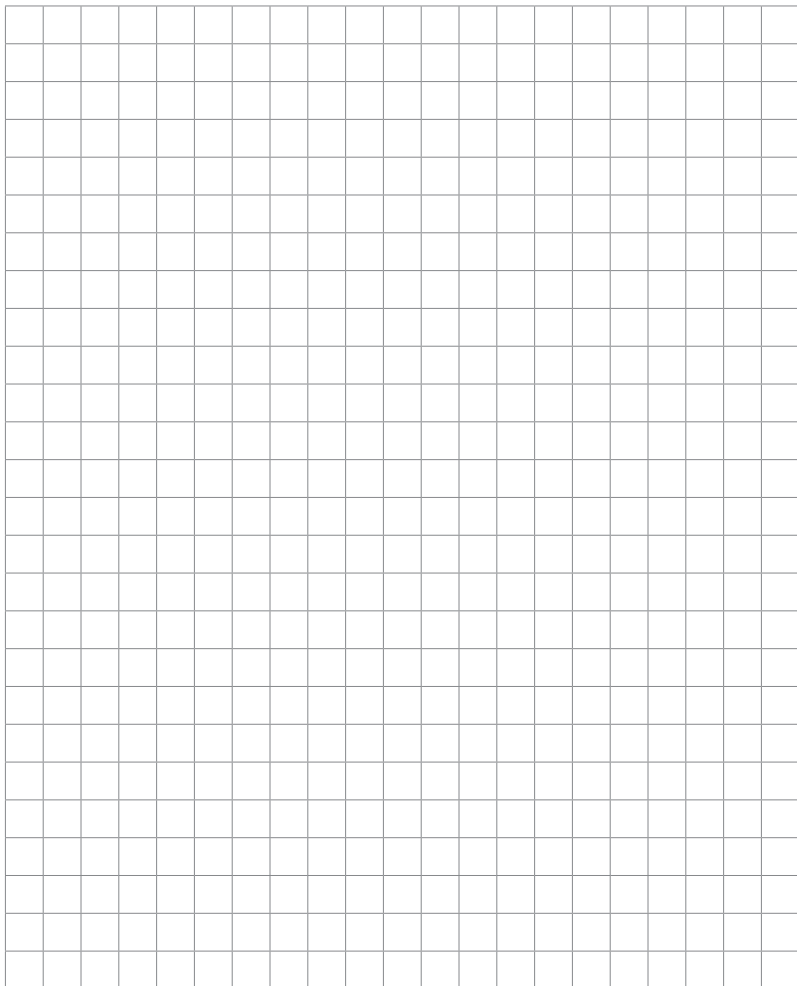

Notes

