

Technical Data

ByStar Fiber

	ByStar Fiber 3015	ByStar Fiber 4020	
Length	11 900	14 200	mm
Width	5 700	6 300	mm
Height	3 200	3 200	mm

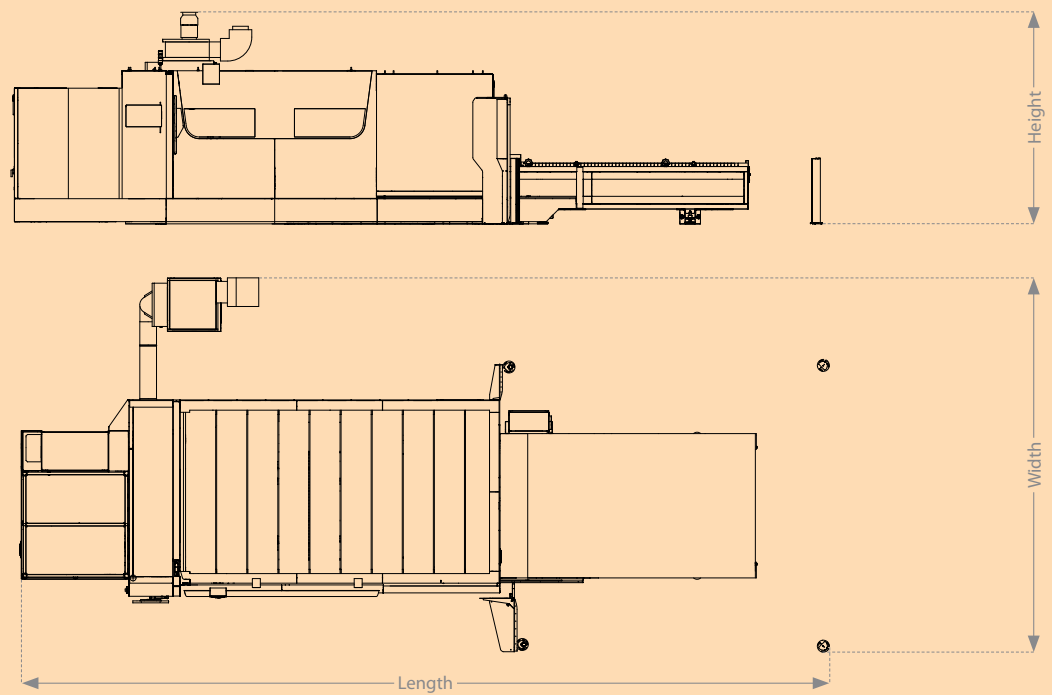

Laser cutting system		ByStar Fiber 3015	ByStar Fiber 4020	
Nominal sheet size	x	3000	4000	mm
	y	1500	2000	
Cutting area	x	3100	4105	mm
	y	1580	2100	
	z	100	100	
Maximum positioning speed parallel axis x, y		120	120	m/min
Maximum simultaneous positioning speed		169	169	m/min
Bilateral repeatability of positioning of one axis R*		0,05	0,05	mm
Averaged, bilateral position deviation of one axis M*		0,1	0,1	mm
Edge detection accuracy		± 0,5	± 0,5	mm
Maximum workpiece weight		1100	1900	kg
Machine weight**		11 000	14 500	kg
Operation via panel		ByVision Touchscreen and manual control unit		

Laser source	Fiber 3000	Fiber 4000	Fiber 6000	Fiber 8000	Fiber 10000	
Power	3000	4000	6000	8000	10000	W
Control range	300–3000	400–4000	600–6000	800–8000	1000–10000	W
Wavelength	Fiber	Fiber	Fiber	Fiber	Fiber	
Maximum sheet thicknesses***						
Steel (max. cutting sheet thickness)	20	20	25	25	25	mm
Stainless steel (max. cutting sheet thickness)	12	15	30	30	30	mm
Aluminum (max. cutting sheet thickness)	12	15	30	30	30	mm
Copper (max. sheet thickness)	6	8	15	15	15	mm
Brass (max. sheet thickness)	6	8	12	12	12	mm
Total electrical consumption of system****	19	21	27	32	36	kW

* Following ISO 230-2:2006(E)

** Entire system without exhaust

*** In order to cut the maximum thicknesses, the following conditions must be met

- optimally maintained and adjusted laser cutting systems
- the materials must be of the quality specified by Bystronic (laser materials)

**** Entire system with exhaust and chiller

The right to make changes to dimensions, construction, and equipment is reserved. ISO-9001-certified.



TRUST PACK FIBER
by Bystronic

* Trust Pack Fiber: Extended warranty on high-quality laser source parts

Bystronic: Best choice.

Laser | Bending | Waterjet
bystronic.com